

TILT - AND - TURN MECHANISM

GALICUBE 150

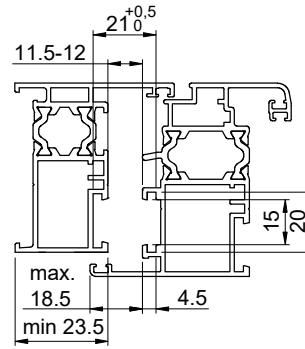
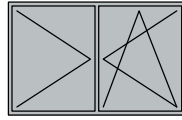
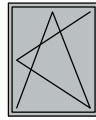
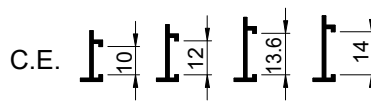

150 Kg

fapim

Life in evolution



ULBZ - Rev.15

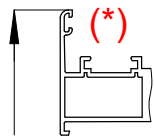

Riferimento - Reference - Référence
 Referencia - Referência - Referenz
 Referentie - Odniesienie - Αναφορά
 Ссылка - Referenca

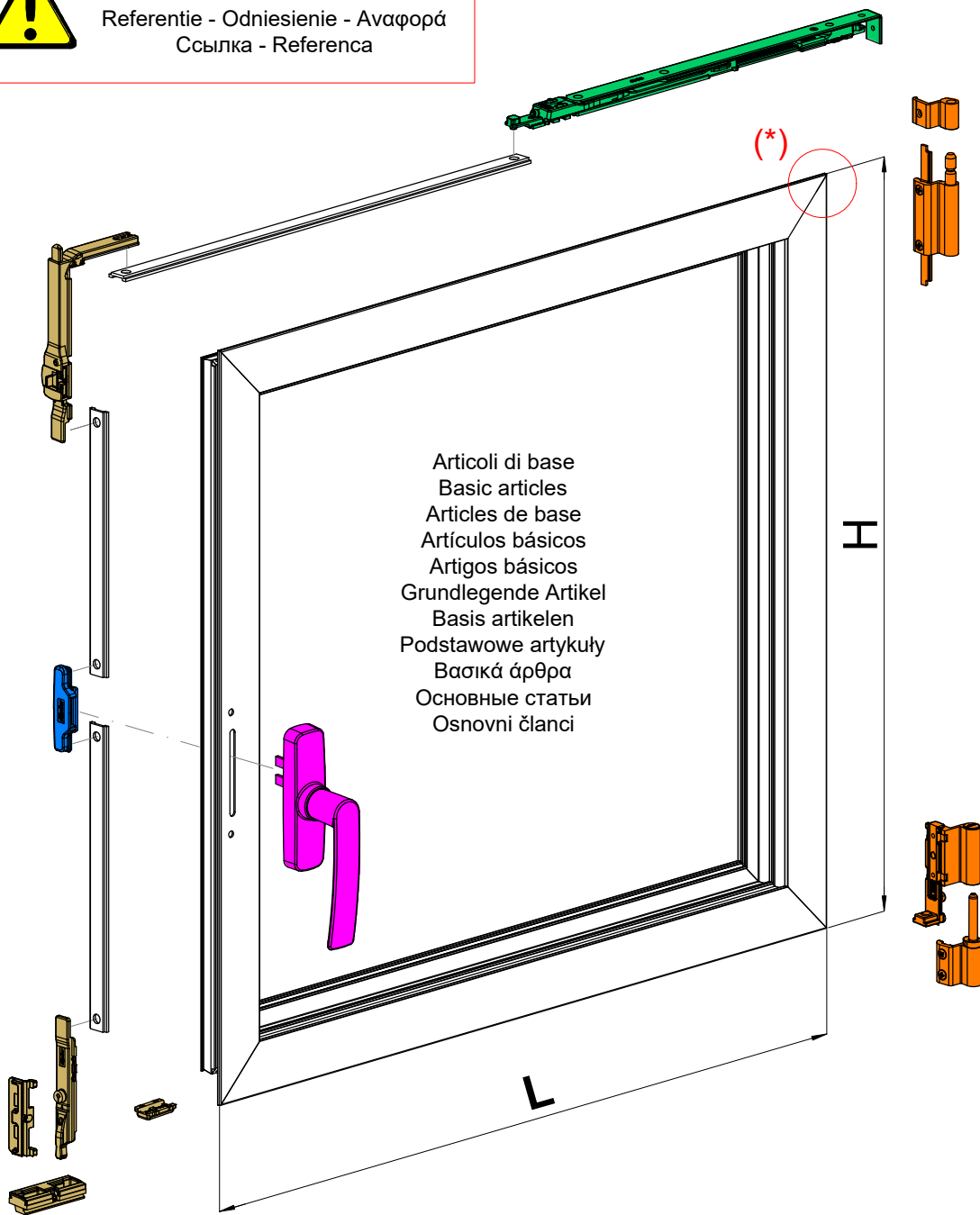

Articoli di base
 Basic articles
 Articles de base
 Artículos básicos
 Artigos básicos
 Grundlegende Artikel
 Basis artikelen
 Podstawowe artykuły
 Βασικά άρθρα
 Основные статьи
 Osnovni članci



fapim
 Life in evolution

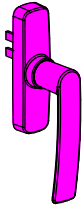

Cremonese e martellina - Cremonese bolt and window handle
 Crémone et poignée - Cremona y manilla
 Cremonese e maçaneta - Einzelgabelgetriebegriff und fenstergriff
 Raamkruk en hendel - Klamka okienna i Klamka
 Σπανιολέτα Και Πόμολο παραθύρου - Ручка с кремальерой и Ручка под редуктор
 Pogonska ručica i Prozorska ručica

Art.0530B	Art.0757B	Art.0760B	Art.0500A	Art.0505A	Art.0510A

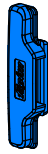

Connessione - Connection
 Connexion - Conexión
 Conexão - Verbindung
 Verbindung - Połączenie
 Σύνδεση - Связь
 Veza

Art.1559	Art.1559A	Art.1558	Art.1563i	Art.1565Ai	Art.1566A	Art.1566B	Art.0520
	 PA						
Art.0650	Art.0651A						

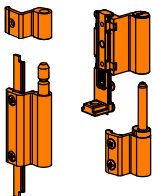

Coppia di cerniere - Pair of hinges
 Paire de paumelles - Par de bisagras
 Par de dobradicas - Bandpaar
 Paar scharnieren - Komplet zawiasow
 Ζεύγος μεντεσέδων - Пара петель
 Par šarki

Kit base - Basic kit
 Kit de base - Kit de base
 Kit basico - Basiskit
 Basiskit - Zestaw podstawowy
 Kit μηχανισμού - Базовый набор
 Osnovni mehanizam

Art.1410A	Art.1414A

Art.1461	Art.1462A

Braccio - Compass arm
 Compas - Compas
 Braco - Kurze
 Korte - Но́жыца
 Ψαλίδι - Ножницы
 Makaze

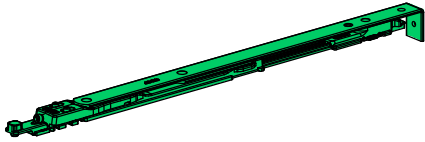

Art.1447

Art.1447A

Art.1447B

Art.1447C



Optionals - Optionals
 Connexion - Conexión
 Conexão - Verbindung
 Verbindung - Połączenie
 Σύνδεση - Связь
 Veza

Art.1581A

Art.1585

Art.1593i

Art.1596C

Art.1596i6

Art.1597i

Art.1495Ai

Art.1497A

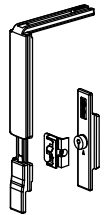
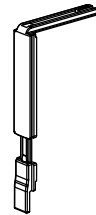
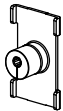
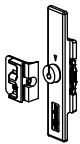
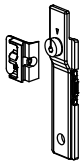

Art.1455

Art.1459

Art.1459B

Art.1459C

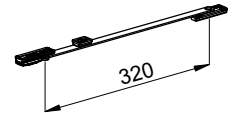
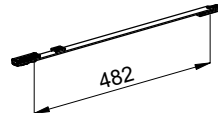
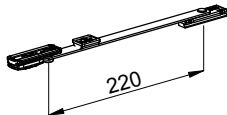
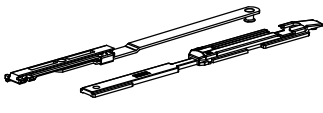

Art.1581H

Art.1500A

Art.1500B

Art.1501

Art.1503A

Art.1503B

Art.1508

Art.1509A

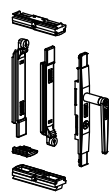
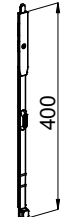
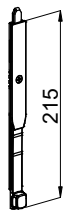
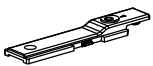

Art.1509B

Art.1509C

Art.1622

Art.1683

Art.1684C

Art.1684D

Art.1689

Art.1685

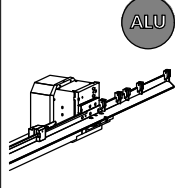
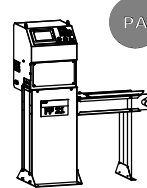
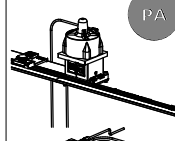
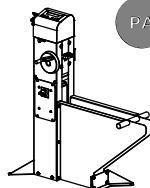
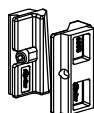

CARATTERISTICHE DEI PROFILATI UTILIZZATI PER GLI INFISSI

Le dimensioni ed il peso massimo indicati nel diagramma di portata sono garantiti solo se i profilati utilizzati per la costruzione dell'infisso abbiano sufficiente resistenza meccanica. Il costruttore si deve assicurare che le dimensioni delle cave sulle quali viene montato il meccanismo consentano il corretto aggancio e fissaggio dei componenti.

FEATURES OF THE PROFILES USED FOR THE FENESTRATION

The dimensions and the weight given in the capacity load diagram can be granted only if the profiles used for the manufacturing of the windows and doors have an enough mechanical resistance. The manufacturer must check that the fastening and clamping of the components can be correct in the grooves where the mechanism is fitted on.

CARACTERISTIQUES DES PROFILES UTILISES POUR LES CHASSIS

Les dimensions et le poids max. indiqués dans le diagramme de portée sont garantis seulement si les profils utilisés pour la fabrication du châssis ont une résistance mécanique suffisante. Le fabricant doit s'assurer que les dimensions des gorges sur lesquelles le mécanisme est assemblé permettent le correct accrochage et fixation des composants.

CARACTERÍSTICAS PERFILES UTILIZADOS PARA LOS MARCOS

Las dimensiones y el peso máximo indicados en el diagrama de capacidad están garantizados sólo si los perfiles utilizados para la construcción del marco tienen bastante resistencia mecánica. El constructor debe asegurarse que las dimensiones de los canales sobre los que se monta el mecanismo permitan un correcto enganche y fijación de los componentes.

CARACTERÍSTICAS DOS PERFIS UTILIZADOS PARA OS CAIXILHOS

As dimensões e o peso máximo indicados no diagrama de capacidade só são garantidos se os perfis utilizados para a construção do caixilho tiverem resistência mecânica suficiente. O construtor deve certificar-se de que as dimensões das cavidades onde vai ser instalado o mecanismo permitem o engate e a fixação correctos dos componentes.

EIGENSCHAFTEN DER PROFILE, DIE FÜR BLENDRAHMEN VERWENDET WERDEN

Die Ausmaße und das Maximalgewicht, welche im Leistungsdiagramm gezeigt sind, werden nur garantiert, wenn die zum Bau des Blendrahmens verwendeten Profile genug mechanische Widerstandskraft haben. Der Hersteller soll sich versichern, daß die Maße der Nute, worauf der Mechanismus montiert wird, eine korrekte Kupplung und Befestigung der Komponenten erlauben.

EIGENSCHAPPEN VAN DE PROFIELEN DIE GEBRUIKT WORDEN VOOR DE KOZIJNEN

De afmetingen en het maximale gewicht dat aangegeven staat in het diagram met de bereikwaarden worden uitsluitend gegarandeerd als de profielen die gebruikt zijn voor de constructie van het kozijn voldoende mechanische resistentie hebben. De aannemer dient ervoor te zorgen dat de afmetingen van de groeven waarop het mechanisme gemonteerd wordt voldoende zijn voor de correcte ophanging en bevestiging van de onderdelen.

PARAMETRY PROFILI UŻYWANYCH DO PRODUKCJI STOLARKI

Maksymalne wymiary i ciężar wskazane w wykresie udźwigu będą gwarantowane pod warunkiem użycia do produkcji stolarki profili o wystarczającej wytrzymałości mechanicznej. Konstruktor musi upewnić się, że wymiary rowków w których zostanie zamontowany mechanizm zezwalają na prawidłowe zaczeplenie i zamocowanie komponentów.

ΧΑΡΑΚΤΗΡΙΣΤΙΚΑ ΤΩΝ ΠΡΟΦΙΛ ΠΟΥ ΧΡΗΣΙΜΟΠΟΙΟΥΝΤΑΙ ΓΙΑ ΤΑ ΚΟΥΦΩΜΑΤΑ

Οι διαστάσεις και το μέγιστο βάρος που υποδεικνύονται στο διάγραμμα ικανότητας, εξασφαλίζονται μόνο αν τα χρησιμοποιούμενα προφίλ για την κατασκευή του κουφώματος διαθέτουν επαρκή μηχανική αντοχή. Ο κατασκευαστής πρέπει να βεβαιωθεί ότι οι διαστάσεις των υποδοχών στις οποίες τοποθετείται ο μηχανισμός επιτρέπουν τη σωστή σύνδεση και στερέωση των εξαρτημάτων.

ΧΑΡΑΚΤΗΡΙΣΤΙΚΑ ΤΩΝ ΠΡΟΦΙΛΕΪ, ΙΣΧΥΟΜΕΝΩΝ ΓΙΑ ΤΗΝ ΚΑΤΑΣΚΕΥΗ ΤΩΝ ΠΑΡΑΘΥΡΩΝ ΚΑΙ ΤΩΝ ΠΥΛΩΝ

Размеры и максимальный вес, указанный в весовой диаграмме, гарантируются если прочность используемых при изготовлении створки окна профилей, абсолютно достаточна. Конструктор должен гарантировать, что размеры паза соответствуют выбранному механизму и позволяют установить и закрепить его, надлежащим образом.

KARAKTERISTIKE PROFILA OD KOJIH SE IZRADJUJU VRATA I PROZORI

Dimenzije i maksimalna nosivost ukazani u dijagramu važe jedino pod uslovom da profili upotrebjeni za izradu vrata i prozora imaju odredjenu mehaničku čvrstinu. Proizvođač vrata i prozora mora prethodno da se uveri da žljeb u koji se sprema da ugradi mehanizme omogućava pravilno postavljanje svih komponenti.

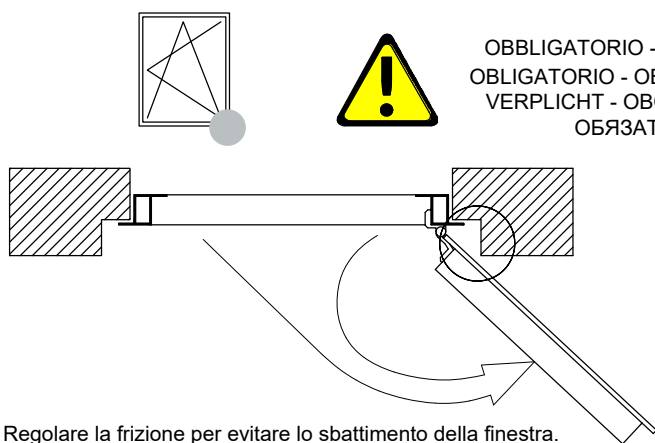

OBBLIGATORIO - MANDATORY - OBLIGATOIRE
OBLIGATORIO - OBRIGATÓRIO - OBLIGATORISCH
VERPLICHT - OBOWIĄZKOWE - ΥΠΟΧΡΕΩΤΙΚΟ
ОБЯЗАТЕЛЬНО - OBAVEZNO

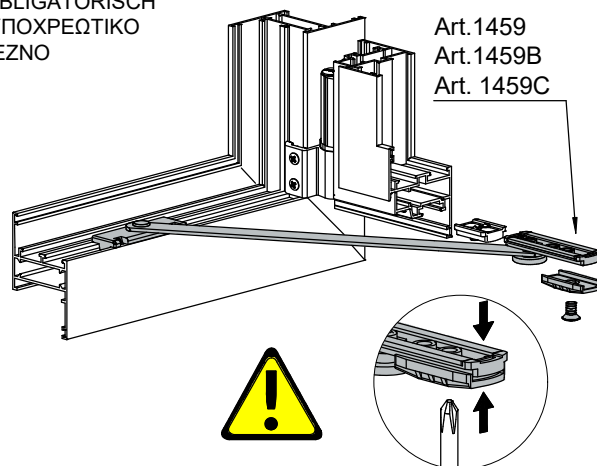

Regolare la frizione per evitare lo sbattimento della finestra.

Adjust clutch to avoid window banging.

Régler la friction pour éviter tout claquement de fenêtre.

Regular la fricción para evitar que la ventana bata

Regular o atrito para evitar o batimento da janela.

Zur Vermeidung eines Anschlagens des

Fensters die Reibkupplung entsprechend einstellen.

Wyregulować stabilizator odchyłu, aby nie dopuścić do gwałtownego uderzenia podczas otwierania okna.

Ρυθμίστε το ψαλίδι έτσι ώστε να αποφύγετε το τσίναγμα του παραθύρου.

Отрегулируйте муфту, чтобы предотвратить захлопывание окна.

Stel het armmechanisme af om te voorkomen dat het raam dichtklipt.



NO !

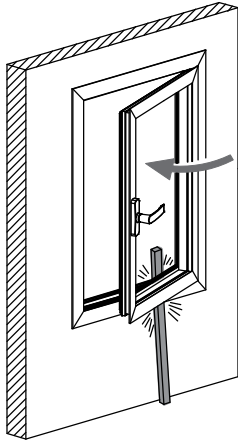

NO !

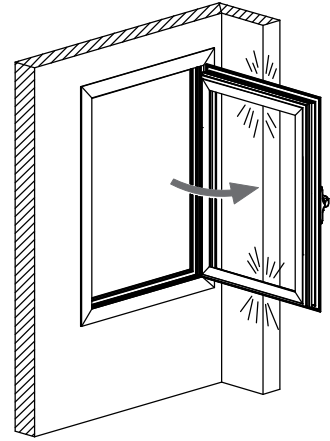

NO !

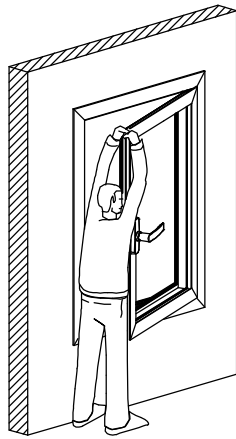

NO !

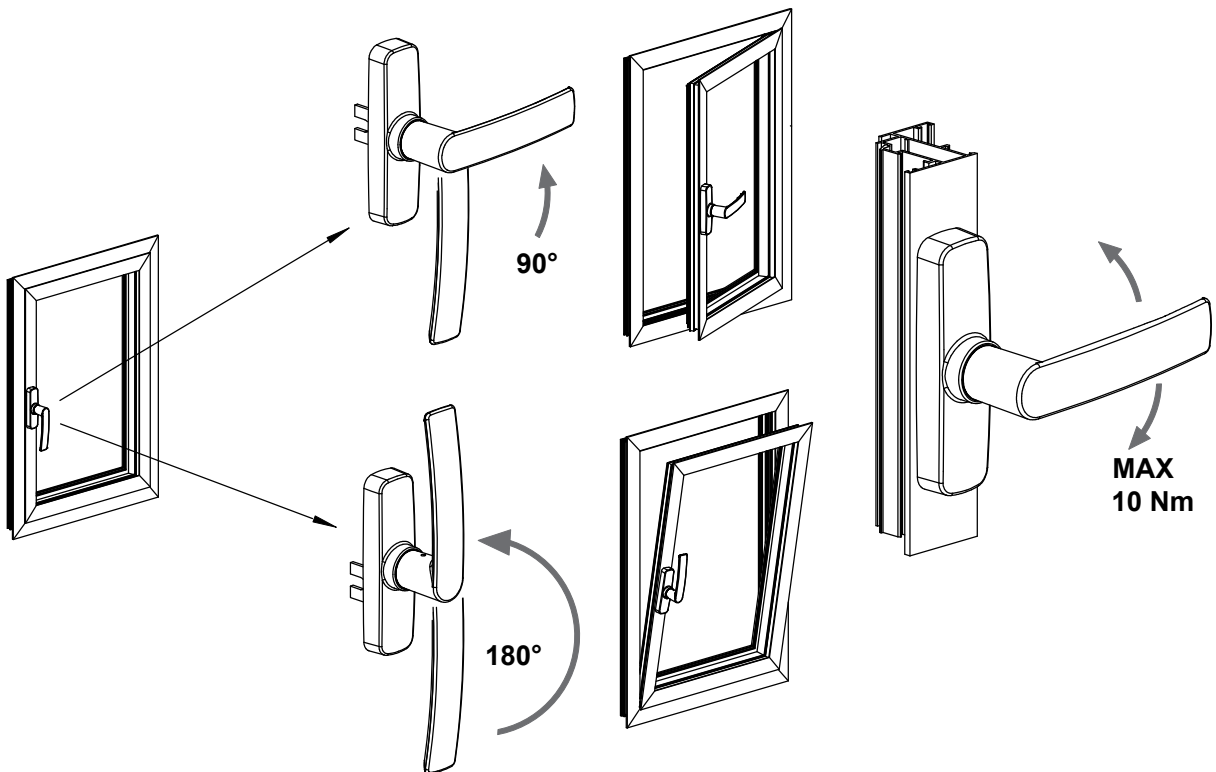
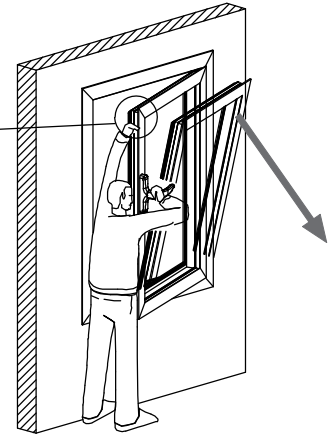
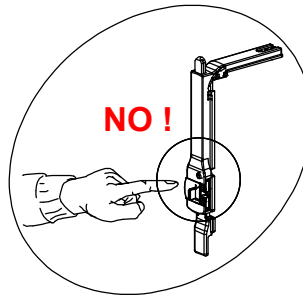

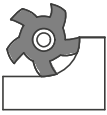

Lavorazioni preliminari - Preliminary machining - Usinage préliminaire - Mecanizado preliminar
 Usinagem preliminar - Vorläufige Bearbeitung - Voorlopige bewerking - Wstępna obróbka
 Προκαταρκτική κατεργασία - Предварительная обработка - Preliminarna obrada

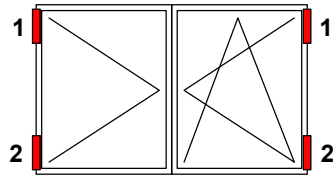
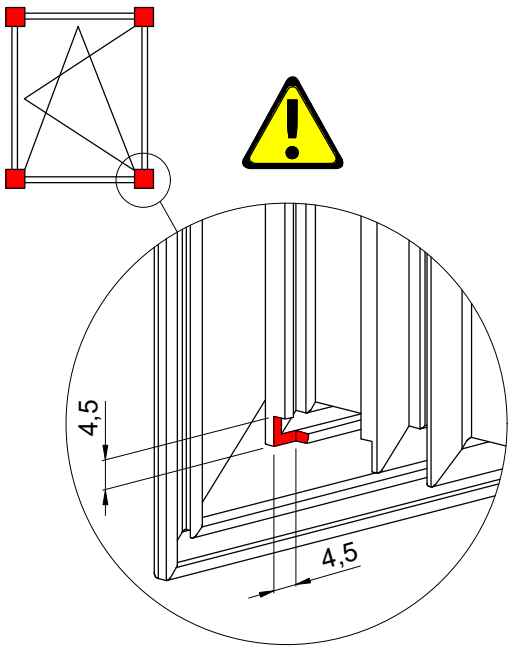

Tagliare la guarnizione se necessario
 If required cut the joint
 Couper le joint si nécessaire
 Cortar la junta si es necesario
 Corte a junta se necessário
 Wenn notwendig, die Dichtung schneiden
 Snijd de afdichting indien nodig bij
 Podciąć uszczelkę jeśli jest to konieczne
 Εάν είναι αναγκαίο, κόψτε την τσιμούχα
 Подрезать уплотнение, если необходимо
 Ukoliko je neophodno odrezati gumu
 dihtovanja

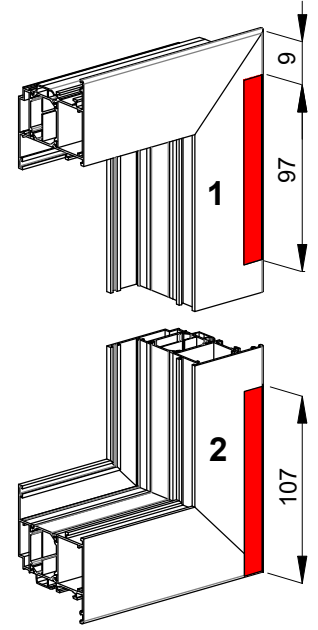

0530B	0757B	0760B	0650+0510A	0651A+0505A	0651A+0510A	0520+0500A	0520+0505A	0520+0510A
			l=43 X=5,3	l=21,5 X=12	l=43 X=12	l=21,5 X=6	l=21,5 X=6	l=43 X=6

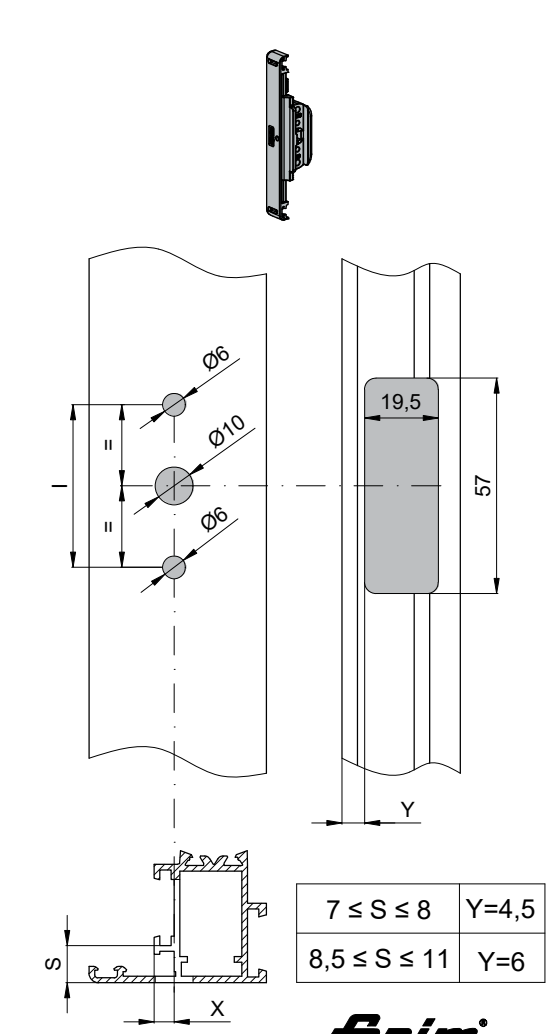
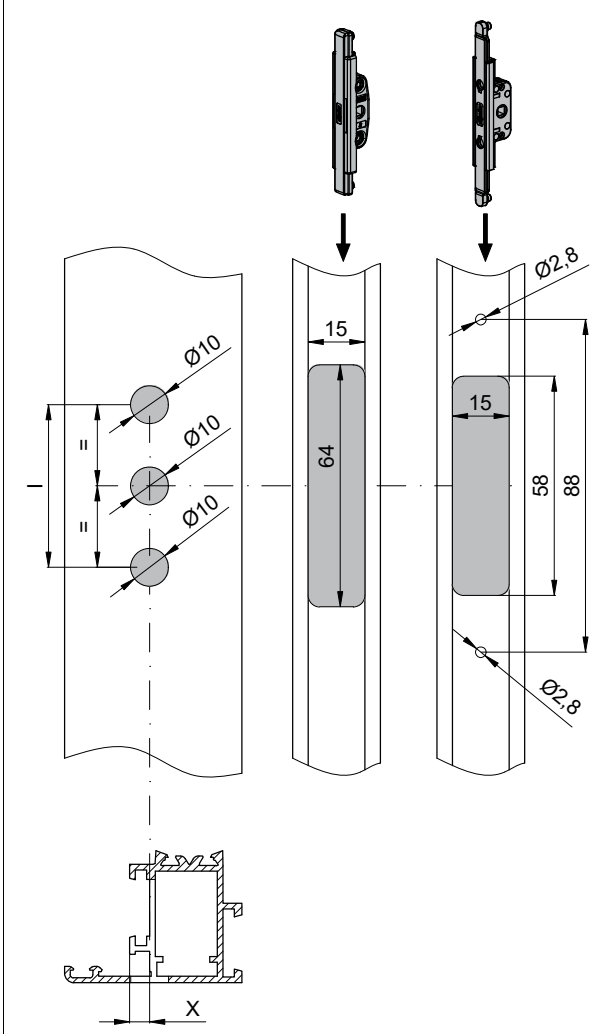
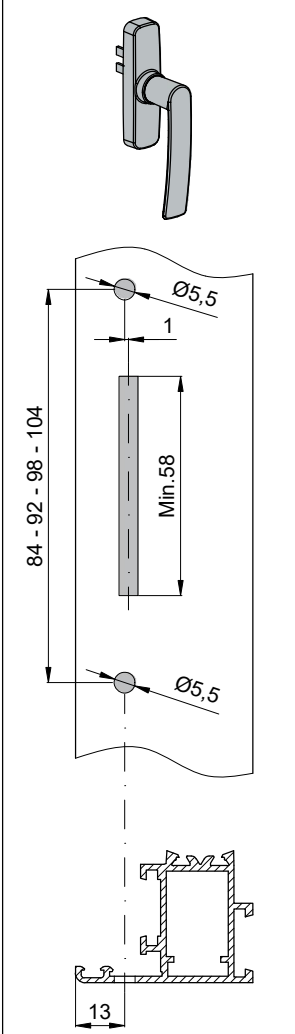

7 ≤ S ≤ 8	Y=4,5
8,5 ≤ S ≤ 11	Y=6

Misure di taglio astine - Rod cutting dimensions - Mesures de coupe des tringles - Medidas de corte de las pletinas
 Medidas de corte do varetas - Stängeschneidende Maßnahmen - Snijden maatregelen stang - Środki cięcia popychacz
 Μέτρα κοπής ντιζα - Меры по разрезанию тяга - Rezanje mera pogonska letvica

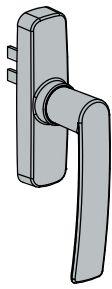

+

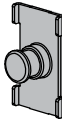

L-1074 (Art.1447C)
 L- 820 (Art.1447B)



1455

ALU PA

L- 750 (Art.1447C)
 L- 496 (Art.1447B)
 L- 372 (Art.1447A)
 L- 334 (Art.1447)

A1

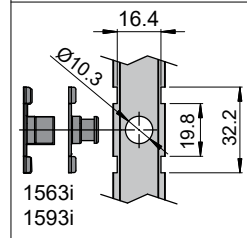
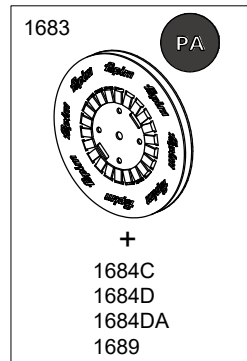
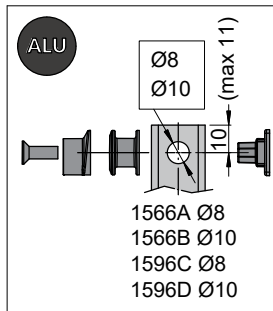

0530B

HB

A2

A2

HB-170

H-296

HC-126

HC (min. 1/4H)

1563i

1565i6

1566A

H

L

Misure di taglio astine - Rod cutting dimensions - Mesures de coupe des tringles - Medidas de corte de las pletinas
 Medidas de corte do varetas - Stängeschneidende Maßnahmen - Snijden maatregelen stang - Środki cięcia popychacz
 Μέτρα κοπής ντιζα - Меры по разрезанию тяга - Rezanje mera pogonska letvica

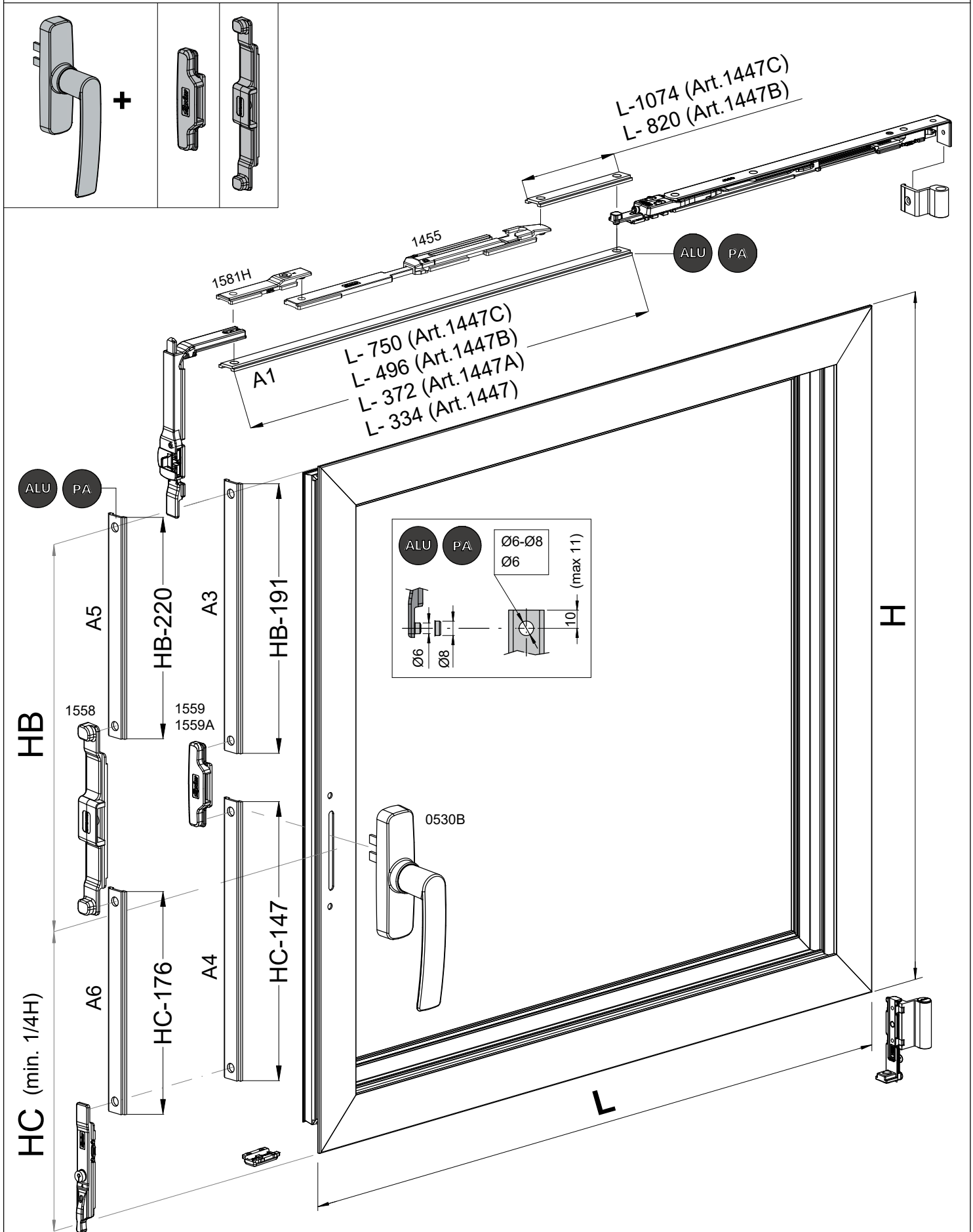

Misure di taglio astine - Rod cutting dimensions - Mesures de coupe des tringles - Medidas de corte de las pletinas
 Medidas de corte do varetas - Stängeschneidende Maßnahmen - Snijden maatregelen stang - Środki cięcia popychacz
 Μέτρα κοπής ντιζα - Меры по разрезанию тяга - Rezanje mera pogonska letvica

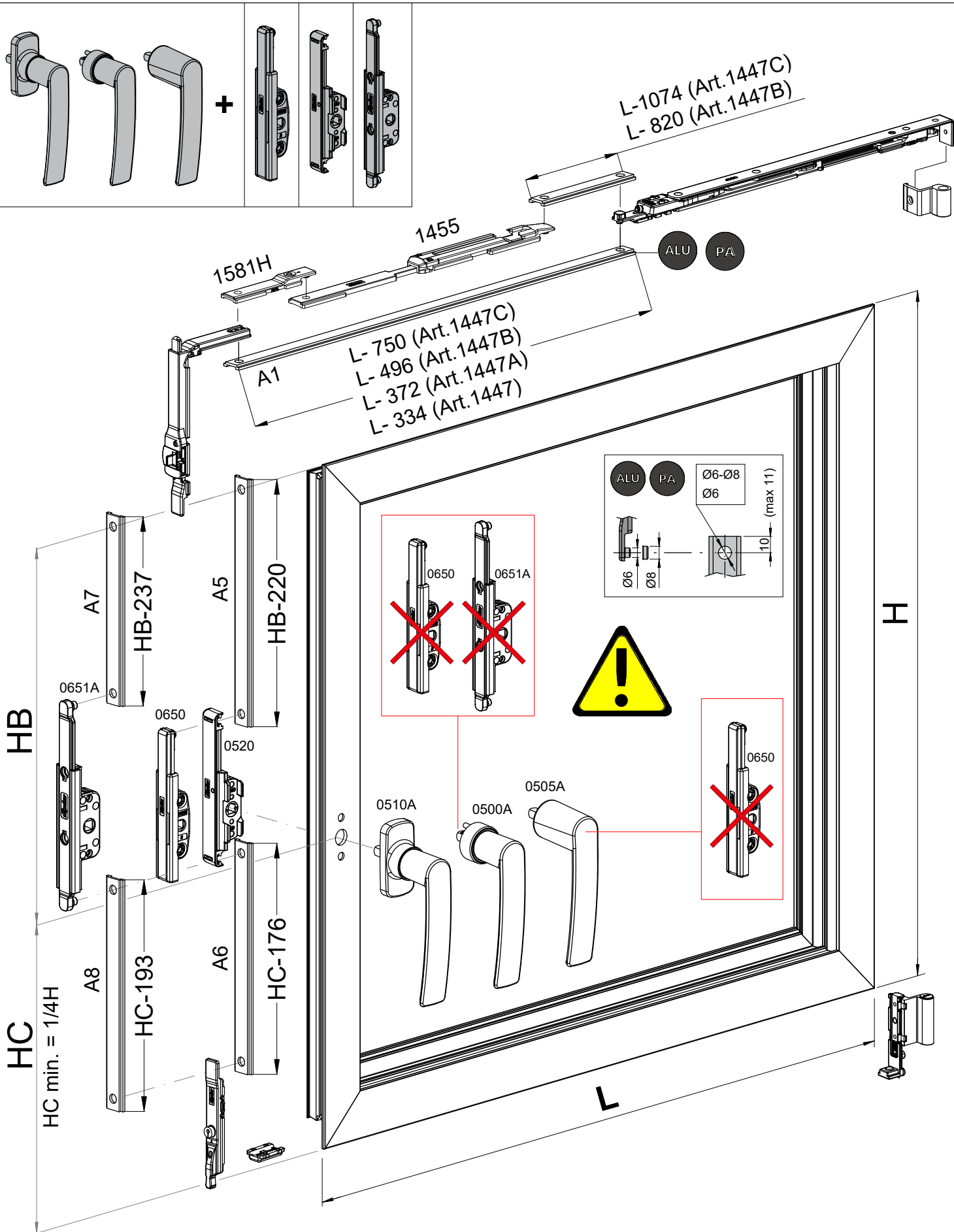



SCELTA DEL NUMERO DEI PUNTI DI CHIUSURA

-I punti di chiusura del sistema GALICUBE sono testati e garantiti fino ad una sollecitazione trasversale di 1200 N (120 Kg). Il numero dei punti di chiusura deve essere scelto tenendo conto della rigidità del profilato, della dimensione della finestra, della pressione del vento.

CHOICE OF THE LOCKING POINTS NUMBER

-The locking points of the GALICUBE system are tested and granted up to a stress of 1200 N (120 Kg.). The number of the locking points must be chosen taking into account of the profile stiffness, the dimensions of the window, and to the wind force.

CHOIX DU NOMBRE DES POINTS DE FERMETURE

-Les points de fermeture du système GALICUBE ont été testé et garantis jusqu'à une charge de 1200 N (120 Kg.). Le nombre des points de fermeture doit être choisi tenant de considération de la rigidité du profil, de la dimension de la fenêtre, de la pression du vent.

ELECCIÓN DEL NÚMERO DE LOS PUNTOS DE CIERRE

-Los puntos de cierre del sistema GALICUBE se han testado y están garantizados hasta una esfuerzo de 1200 N (120 Kg.). El número de los puntos de cierre debe ser elegido teniendo en cuenta la rigidez del perfilado, de las dimensiones de la ventana y de la presión del viento.

ESCOLHA DO NÚMERO DE PONTOS DE FECHO

-Os pontos de fecho do sistema GALICUBE são testados e garantidos para uma solicitação até 1200 N (120 Kg). O número de pontos de fecho deve ser escolhido tendo em conta a rigidez do perfil, as dimensões da janela, a pressão do vento.

BESTIMMUNG DER ZAHL DER VERSCHLUSSPUNKTE

-Die Verschlusspunkte des „GALICUBE“-Systems sind mit einer Belastung bis 1200 N (120 Kg) geprüft und garantiert. Die Anzahl der Verschlusspunkte soll mit Bezug auf die Starrheit des Profils, das Ausmaß des Fensters und den Winddruck bestimmt werden.

SELECTIE VAN HET AANTAL SLUITINGSPUNTEN

-De sluitingspunten van het GALICUBE-systeem zijn getest en gegarandeerd tot een belasting van 1200 N (120 kg). Het aantal sluitingspunten moet gekozen worden rekening houdend met de hardheid van het profiel, de afmetingen van het raam en de druk van de wind.

WYBÓR ILOŚCI PUNKTÓW BLOKUJĄCYCH

-Punkty blokujące systemu GALICUBE są gwarantowane i testowane aż do nacisku 1200 N (120 Kg). Ilość punktów blokujących powinna być dobierana w oparciu o sztywność profilu, wymiary okna oraz siłę wiatru.

ΕΠΙΛΟΓΗ ΑΡΙΘΜΟΥ ΣΗΜΕΙΩΝ ΚΛΕΙΔΩΜΑΤΟΣ

-Τα σημεία κλειδώματος του συστήματος GALICUBE είναι δοκιμασμένα και εγγυημένα έως τα 1200 N (120 Kg). Ο αριθμός των σημείων κλειδώματος πρέπει να επιλέγεται λαμβάνοντας υπόψη την ακαμψία του προφίλ, τις διαστάσεις του παραθύρου και την πίεση του ανέμου.

ВЫБОР КОЛИЧЕСТВА ТОЧЕК ЗАПИРАНИЯ

-Точки запираения системы GALICUBE были протестированы и выдерживают поперечную нагрузку до 1200н (120кг). количество точек запираения должно быть выбрано исходя из жесткости профиля, размеров окна и ветрового давления, соответствующей зоны.

IZBOR BROJA DOPUNSKIH TAČKI ZATVARANJA

-Tačke zatvaranja sistema GALICUBE su testirane do i garantuju izdržljivost na poprečnu silu od 1200N (120kg). Broj tački zatvaranja mora da se odluči vodeći računa o čvrstini profila, dimenzijama prozora i pritisku i udarima vetra u zoni montaže i upotrebe.

Indicazioni generali in base alle dimensioni - General indications according to the size - Indications générales selon la taille
 Indicaciones generales según tamaño - Indicações gerais de acordo com o tamanho - Allgemeine Angaben je nach Größe
 Algemene indicaties volgens maat - Ogólne wskazania w zależności od rozmiaru - Γενικές ενδείξεις ανάλογα με το μέγεθος
 Общие указания на основе размеров - Opšte indikacije prema veličini

1200 < L < 1700

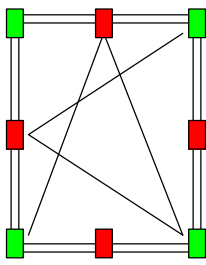

1400 < H < 1800

1200 < L < 1700

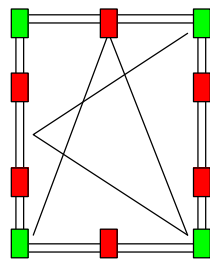

1800 < H < 3000

 Punto di chiusura supplementare - Additional locking point
 Point de fermeture supplémentaire - Punto de cierre suplementario
 Ponto de fecho suplementar - Zusatzverschluss punkt
 Supplementaire sluitpunt - Dodatkowy punkt blokujący
 Πρόσθετο σημείο κλειδώματος - Дополнительный запорный набор
 Tačka dopunskog zatvaranja

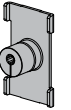

A1 - A9 - A11 - A12

A1 - A10 - A11 - A13

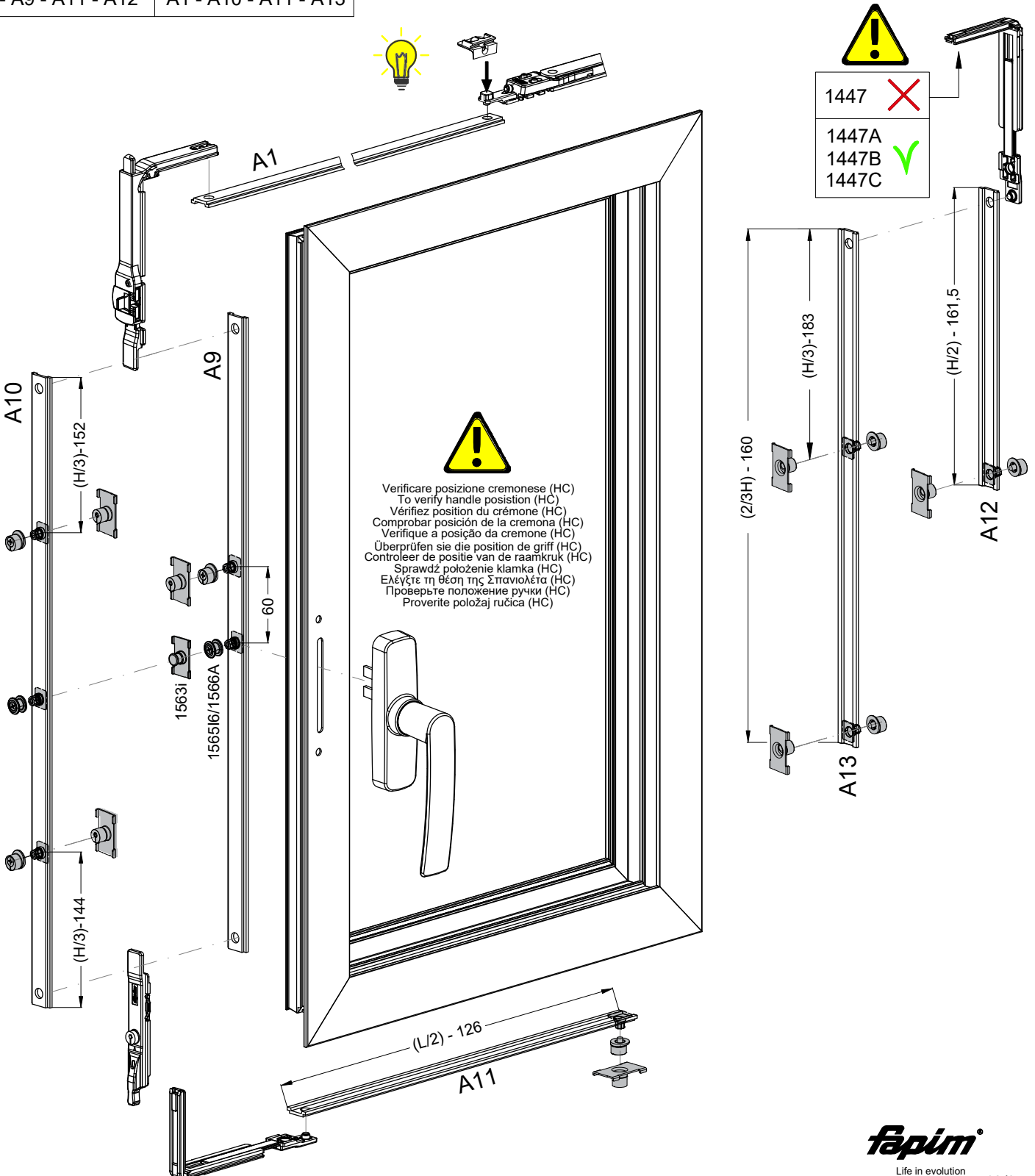

Indicazioni generali in base alle dimensioni - General indications according to the size - Indications générales selon la taille
 Indicaciones generales según tamaño - Indicações gerais de acordo com o tamanho - Allgemeine Angaben je nach Größe
 Algemene indicaties volgens maat - Ogólne wskazania w zależności od rozmiaru - Γενικές ενδείξεις ανάλογα με το μέγεθος
 Общие указания на основе размеров - Opšte indikacije prema veličini

1200 < L < 1700

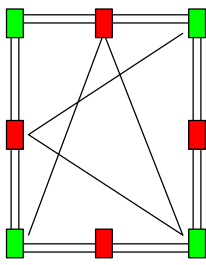

1400 < H < 1800

1200 < L < 1700

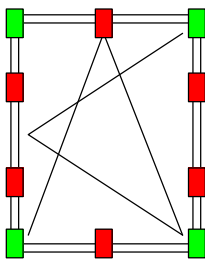

1800 < H < 3000

Punto di chiusura supplementare - Additional locking point
Point de fermeture supplémentaire - Punto de cierre suplementario
Ponto de fecho suplementar - Zusatzverschluss punkt
Supplementaire sluitpunt - Dodatkowy punkt blokujący
Πρόσθετο σημείο κλειδώματος - Дополнительный запорный набор
Tačka dopunskog zatvaranja

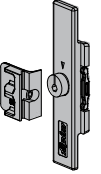

A1 - A3/4 - A5/6 - A14
A15

A1 - A18 - A19/22
A20/23 - A21 - A14
A16 - A17



1447 ~~X~~
 1447A
 1447B ✓
 1447C

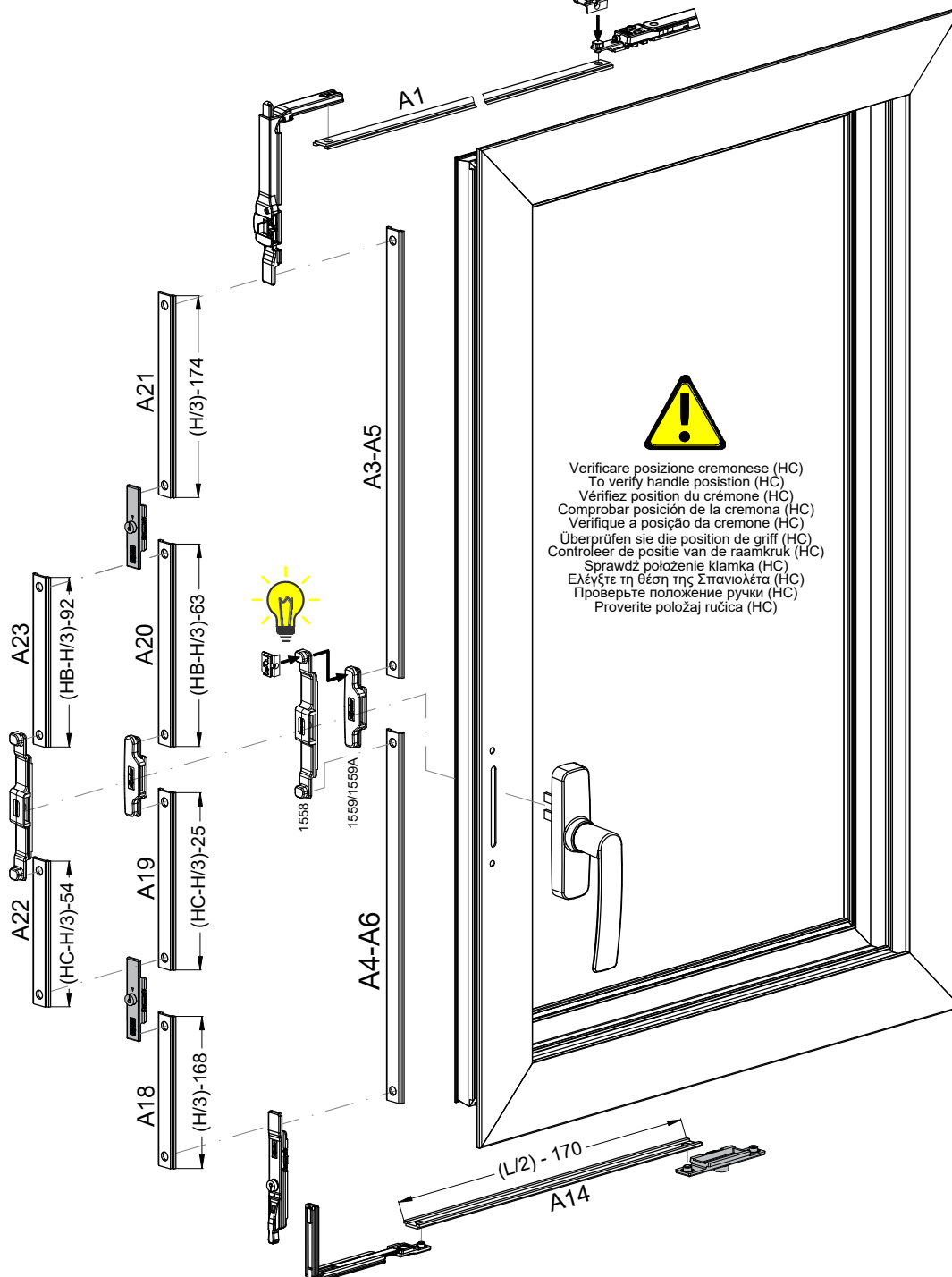

Verificare posizione cremone (HC)
To verify handle position (HC)
Vérifiez position du crémonne (HC)
Comprobar posición de la cremone (HC)
Verifique a posição da cremone (HC)
Überprüfen sie die position de griff (HC)
Controleer de positie van de raamkruk (HC)
Sprawdz położenie klamka (HC)
Ελέγξτε τη θέση της Σπανιολέτα (HC)
Проверьте положение ручки (HC)
Proverite položaj ručica (HC)

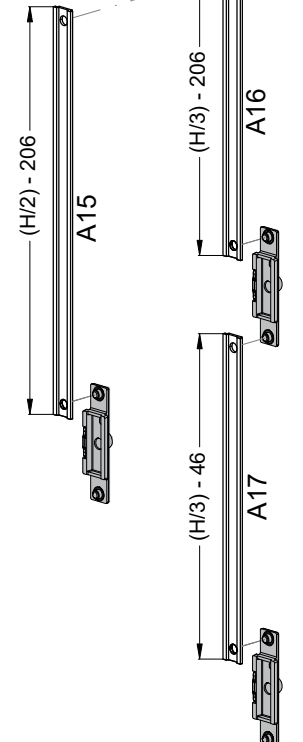

Indicazioni generali in base alle dimensioni - General indications according to the size - Indications générales selon la taille
 Indicaciones generales según tamaño - Indicações gerais de acordo com o tamanho - Allgemeine Angaben je nach Größe
 Algemene indicaties volgens maat - Ogólne wskazania w zależności od rozmiaru - Γενικές ενδείξεις ανάλογα με το μέγεθος
 Общие указания на основе размеров - Opšte indikacije prema veličini

1200 < L < 1700

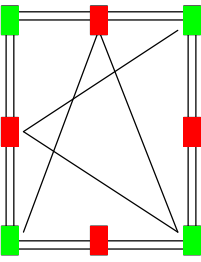

1400 < H < 1800

1200 < L < 1700

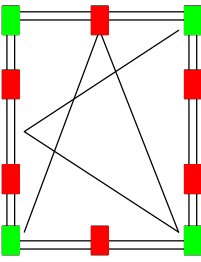

1800 < H < 3000

Punto di chiusura supplementare - Additional locking point
Point de fermeture supplémentaire - Punto de cierre suplementario
Ponto de fecho suplementar - Zusatzverschluss punkt
Supplementaire sluitpunt - Dodatkowy punkt blokujący
Πρόσθετο σημείο κλειδώματος - Дополнительный запорный набор
Tačka dopunskog zatvaranja

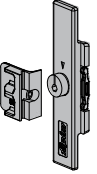



A1 - A6/8 - A7/24
A14 - A15

A1 - A18 - A22/24
A23/25 - A21 - A14
A16 - A17

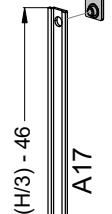
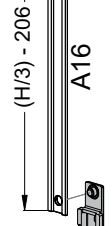
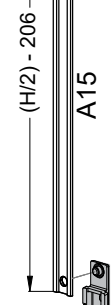
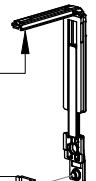

1447 
 1447A 
 1447B
 1447C



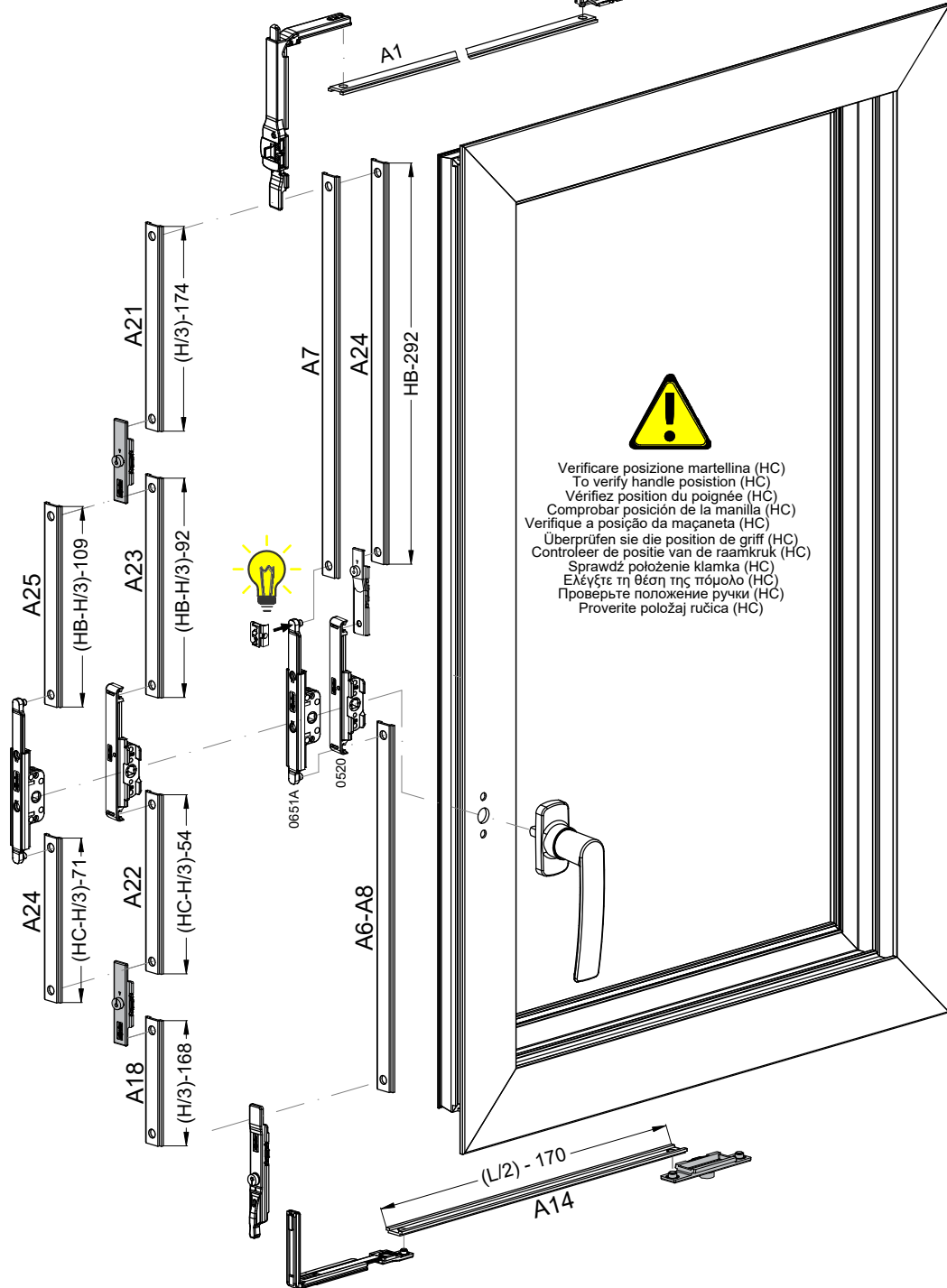

 Verificare posizione martellina (HC)
 To verify handle position (HC)
 Vérifiez position du poignée (HC)
 Comprobar posición de la manilla (HC)
 Verifique a posição da maçaneta (HC)
 Überprüfen sie die position de griff (HC)
 Controleer de positie van de raamkruk (HC)
 Sprawdź położenie klamka (HC)
 Ελέγξτε τη θέση της πόμολο (HC)
 Проверьте положение ручки (HC)
 Proverite položaj ručica (HC)

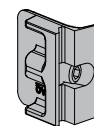

Indicazioni generali in base alle dimensioni - General indications according to the size - Indications générales selon la taille
 Indicaciones generales según tamaño - Indicações gerais de acordo com o tamanho - Allgemeine Angaben je nach Größe
 Algemene indicaties volgens maat - Ogólne wskazania w zależności od rozmiaru - Γενικές ενδείξεις ανάλογα με το μέγεθος
 Общие указания на основе размеров - Opšte indikacije prema veličini

1597i



1200 < L < 1700

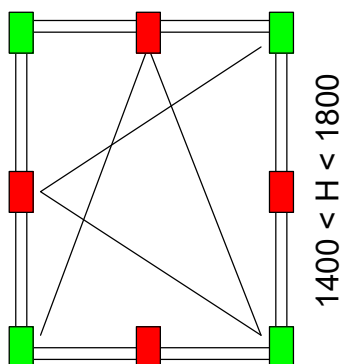

Punto di chiusura supplementare - Additional locking point
 Point de fermeture supplémentaire - Punto de cierre suplementario
 Ponto de fecho suplementar - Zusatzverschluss punkt
 Suplementaire sluitpunt - Dodatkowy punkt blokujący
 Πρόσθετο σημείο κλειδώματος - Дополнительный запорный набор
 Tačka dopunskog zatvaranja

1400 < H < 1800

665 (art.1447C)
 412 (art.1447B)

Posizione incontro
 Keeper position
 Position gâche
 Posición cerradero
 Posição encontro
 Gegenstück stellung
 Sluitplaat positie
 Lokalizacja zaczer
 Θέση Φωλιά
 Положение ответная планка
 Prihvatnik položaj

HC+118 (Art. 0520/0650+1581A)
 HC+84 (Art. 0651A)



HC+52 (Art. 1566A)
 HC + 35 (art.1559 / 1559A)
 HC + 66 (art.1558)

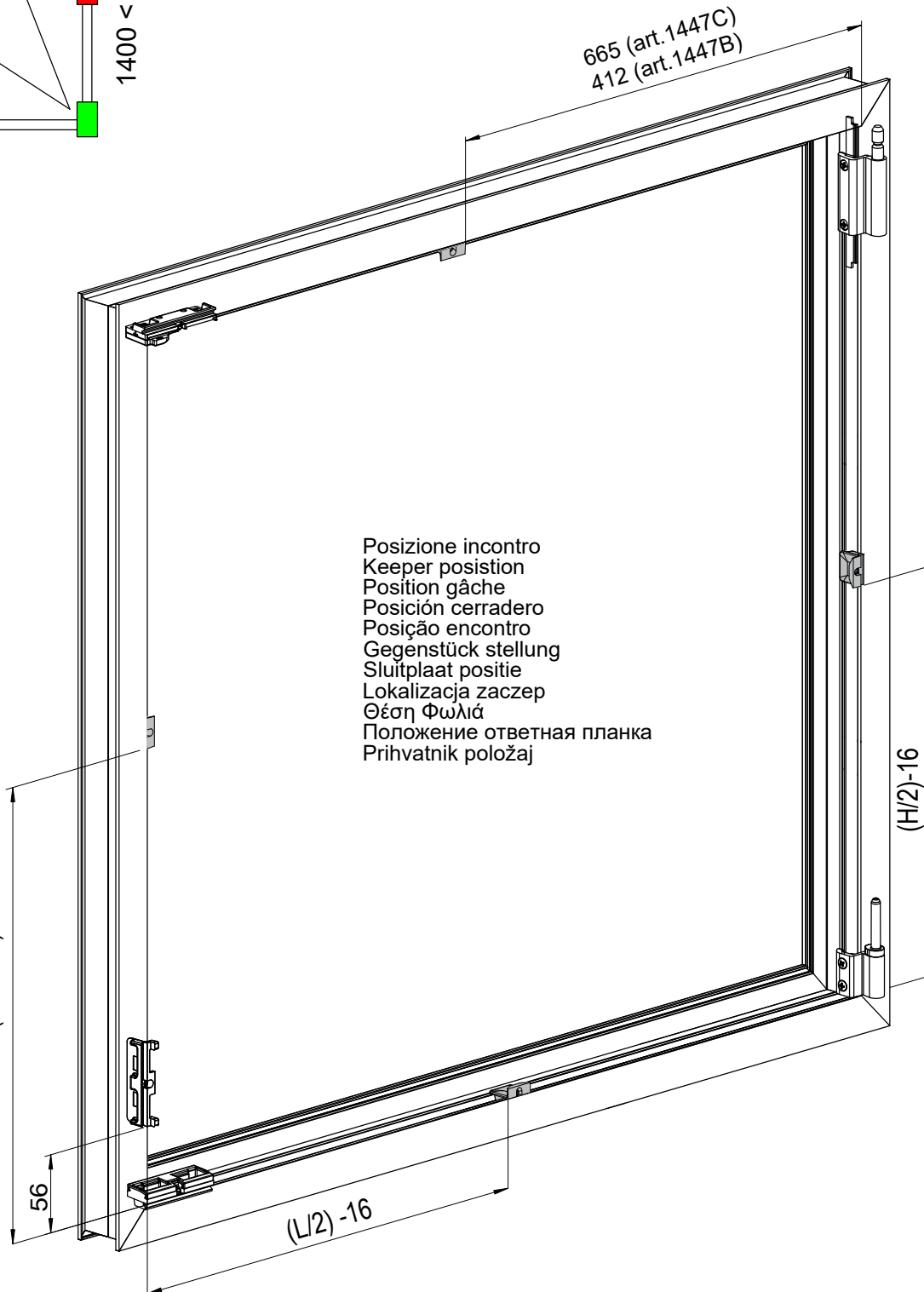

Indicazioni generali in base alle dimensioni - General indications according to the size - Indications générales selon la taille
 Indicaciones generales según tamaño - Indicações gerais de acordo com o tamanho - Allgemeine Angaben je nach Größe
 Algemene indicaties volgens maat - Ogólne wskazania w zależności od rozmiaru - Γενικές ενδείξεις ανάλογα με το μέγεθος
 Общие указания на основе размеров - Opšte indikacije prema veličini

1597i

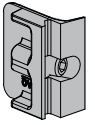

1200 < L < 1700

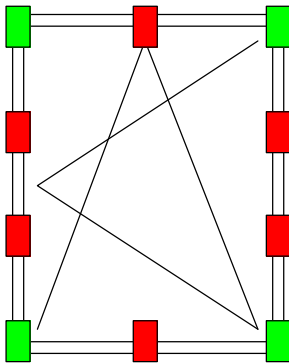

1800 < H < 3000

Punto di chiusura supplementare - Additional locking point
 Point de fermeture supplémentaire - Punto de cierre suplementario
 Ponto de fecho suplementar - Zusatzverschluss punkt
 Suplementaire sluitpunt - Dodatkowy punkt blokujący
 Πρόσθετο σημείο κλειδώματος - Дополнительный запорный набор
 Tačka dopunskog zatvaranja

665 (art.1447C)
 412 (art.1447B)

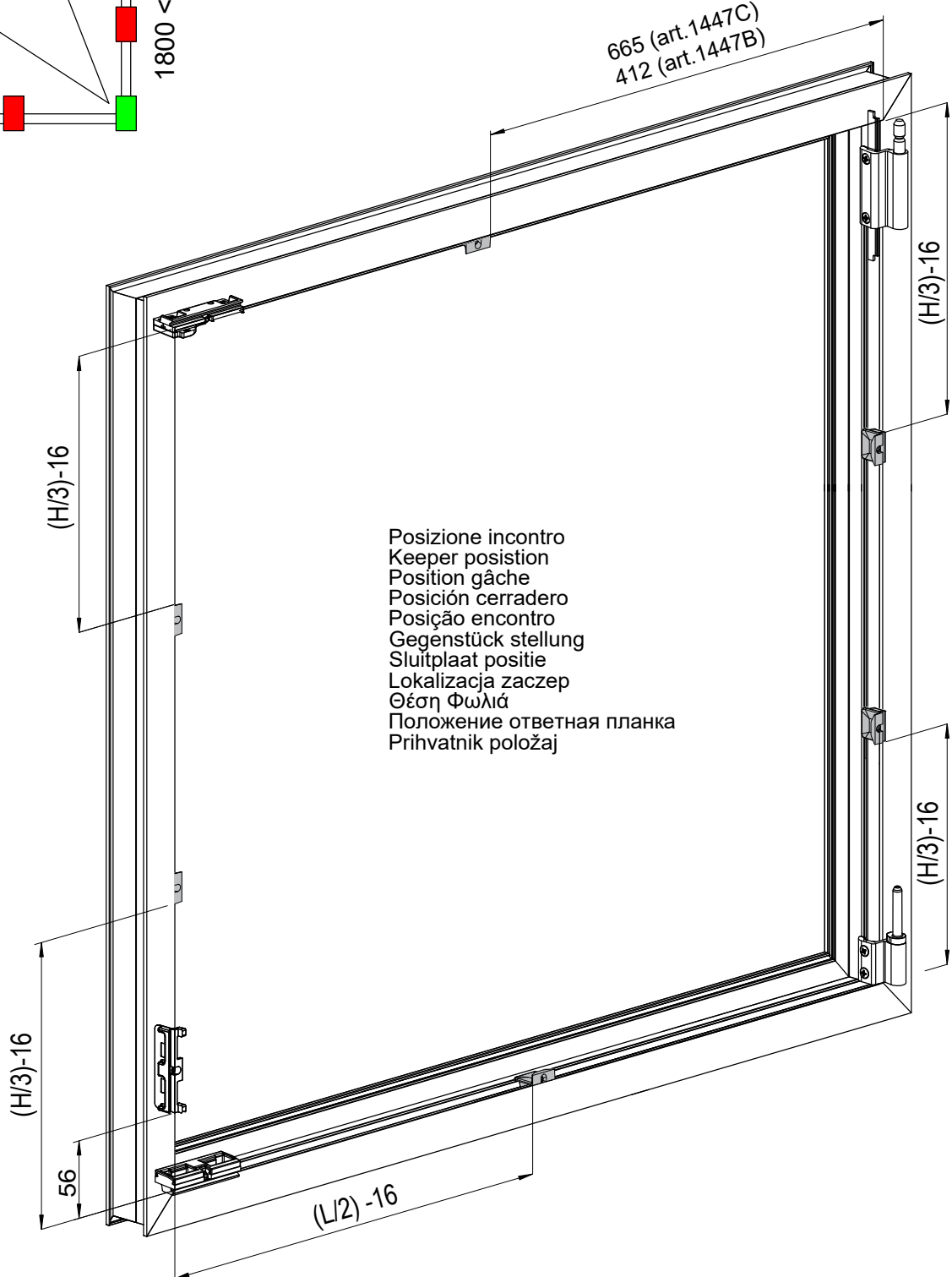

Posizione incontro
 Keeper position
 Position gâche
 Posición cerradero
 Posição encontro
 Gegenstück stellung
 Sluitplaat positie
 Lokalizacja zaczer
 Θέση Φωλιά
 Положение ответная планка
 Prihvatnik položaj

1410A

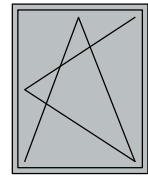
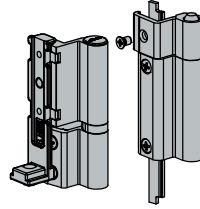
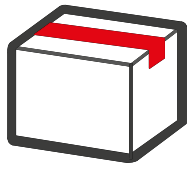
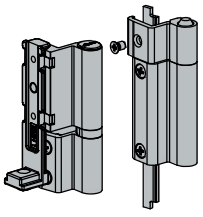

R

L

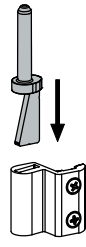
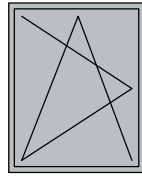

1

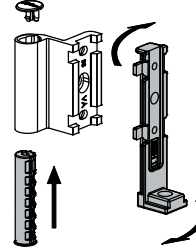

2

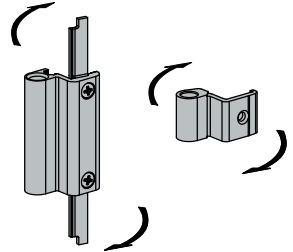

3

1461

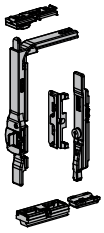

1462A

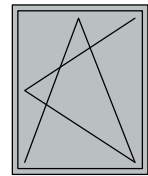
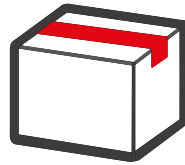
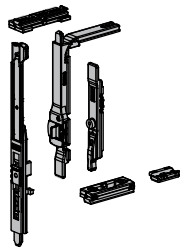

R

L

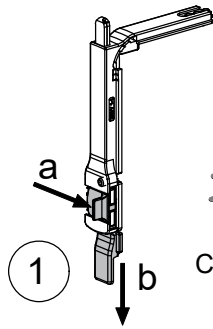
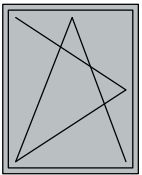

1

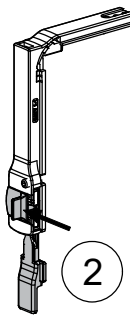

2

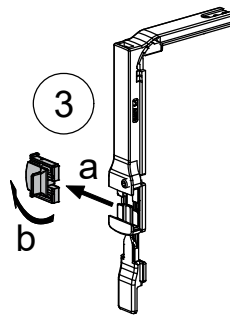

3

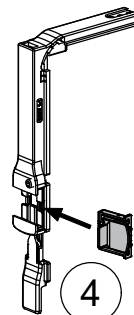

4

CLICK

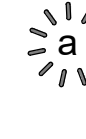

a b c

L

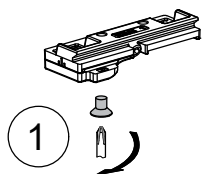
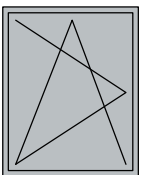

1

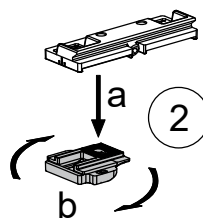

2

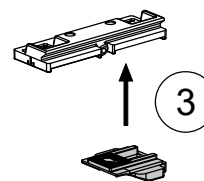

3

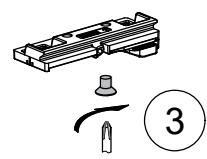

3



Art.	L _{min}	L _{max}	H _{min}	H _{max}
1447	364	700	450	1800
1447A	402	750	500	2400
1447B	562	1200	700	3000
1447C	816	1700	700	3000
1447B+1455+1581H	860	1200	700	3000
1447C+1455+1581H	1114	1700	700	3000

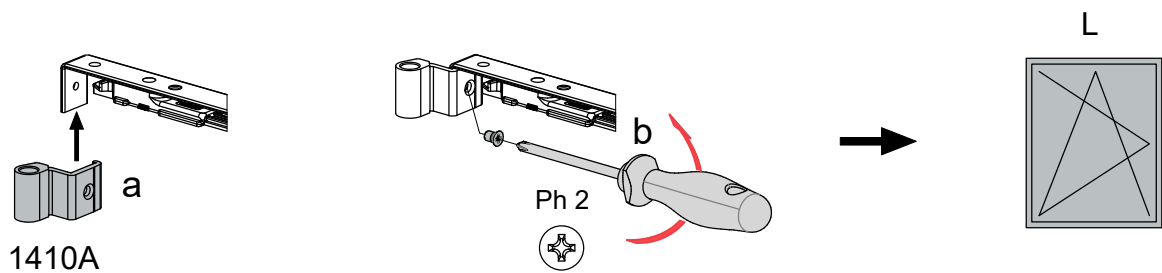
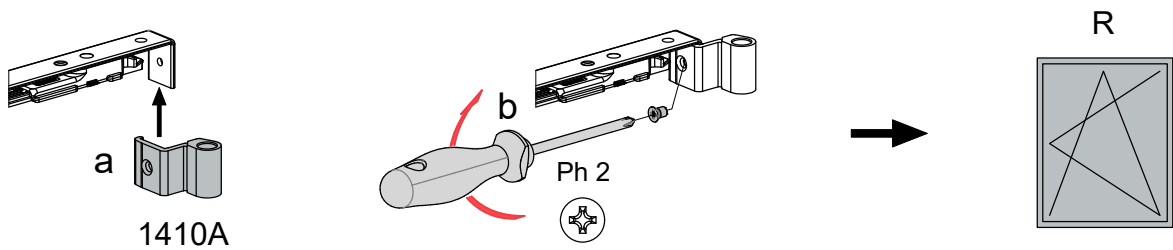

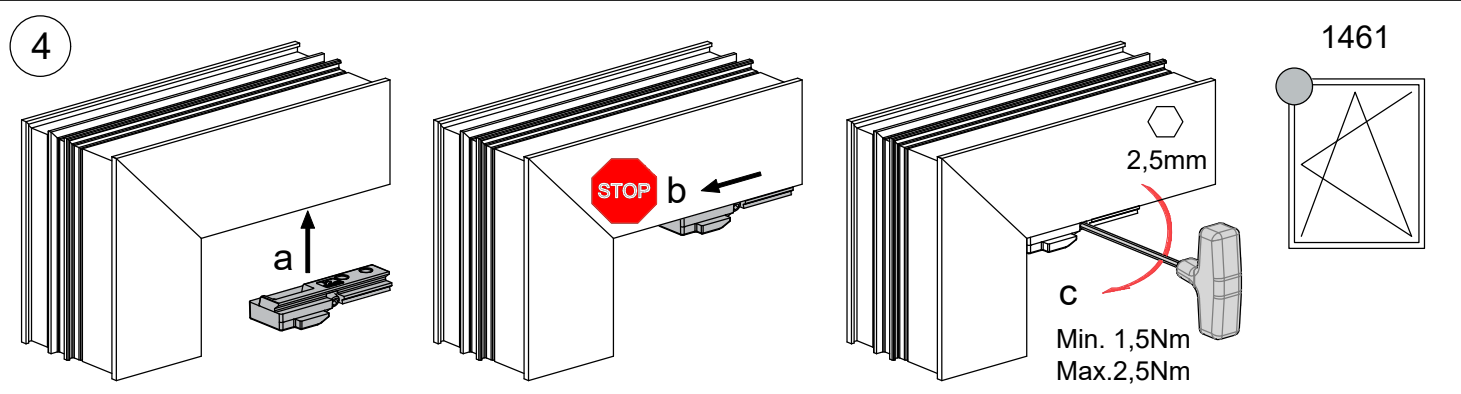
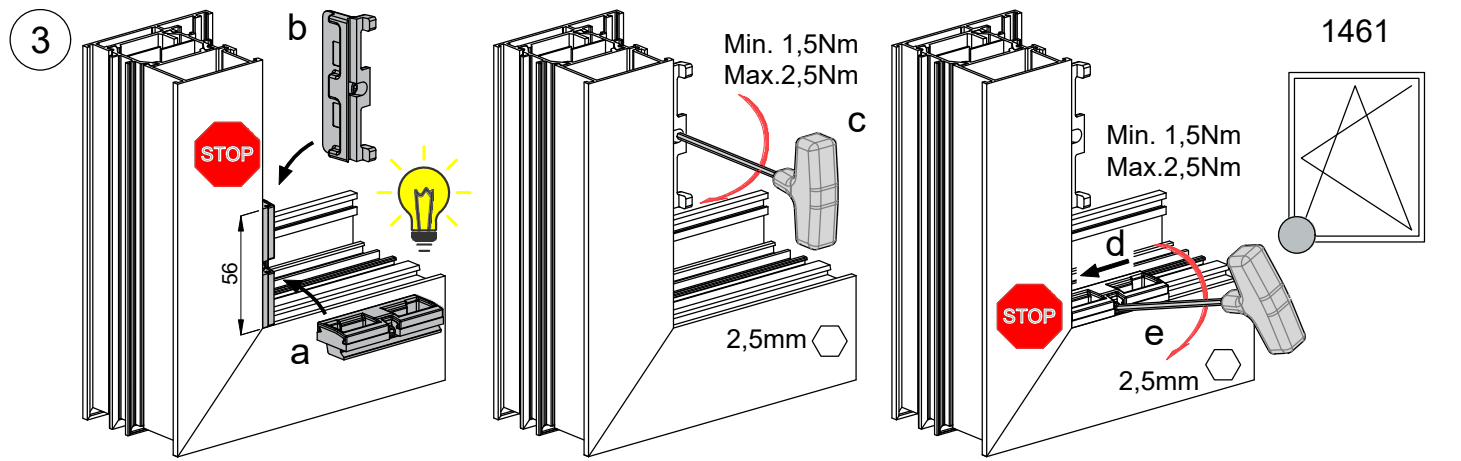
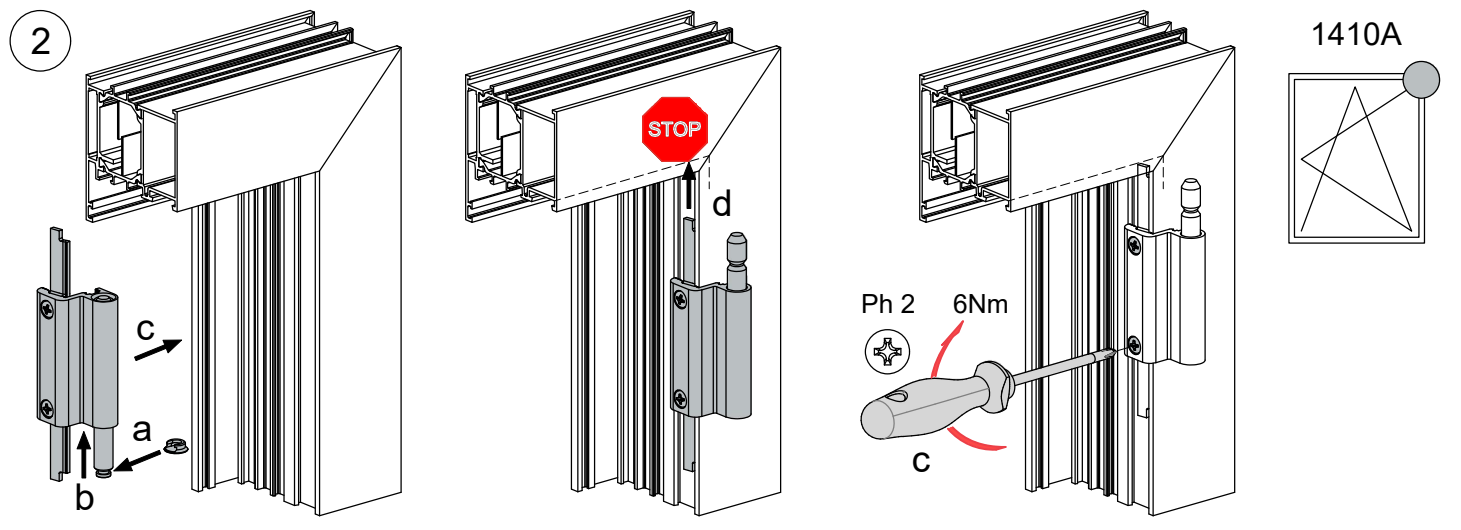
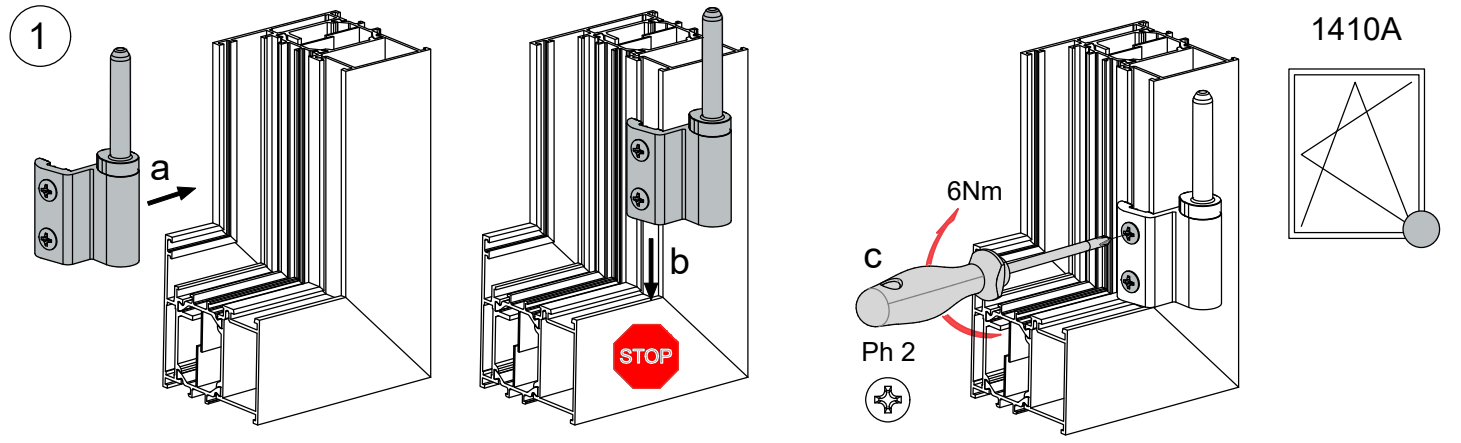

Montaggio accessori anta - Sash hardware assembly - Assemblage des accessoires de ouvrant- Montaje de accesorios de hoja
 Montagem de acessórios de folha - Montage von Flügelzubehör - Montage van Vleugelaccessoires - Montaż akcesoriów do skrzydła
 Συγκρότημα αξεσουάρ φύλλου - Установка фурнитуры на створки - Montaža pribora za krilo

1495Ai

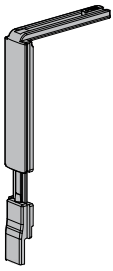

1497A

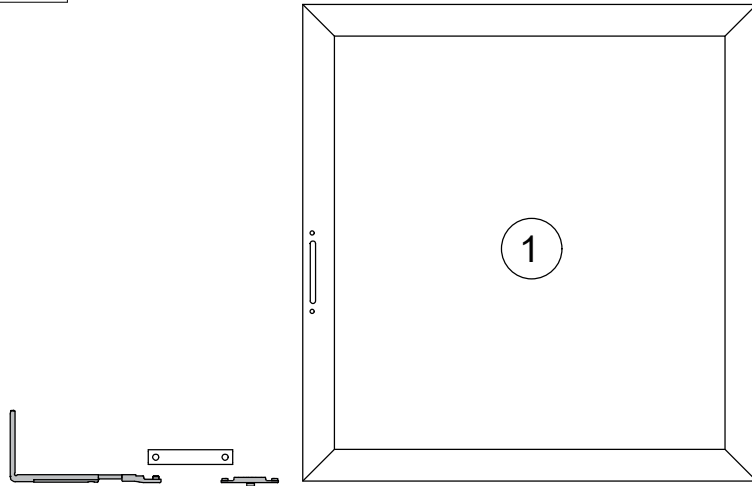
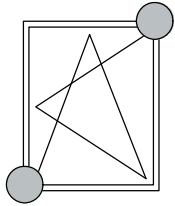
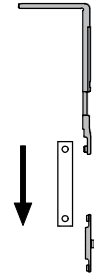
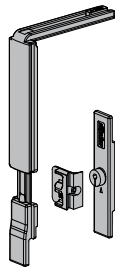

2

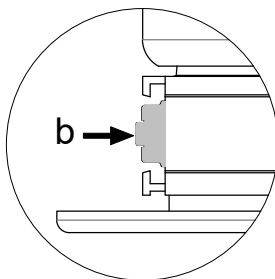

STOP

a

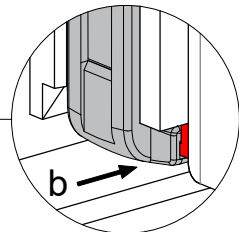
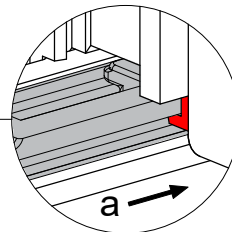
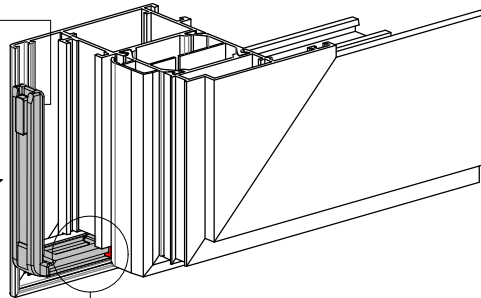

STOP

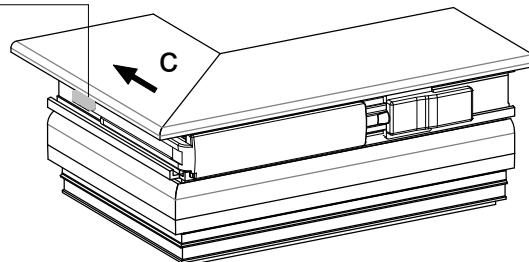
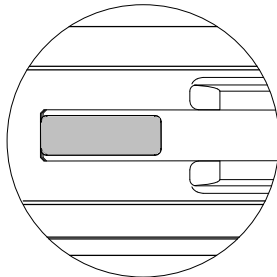

3

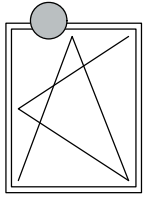
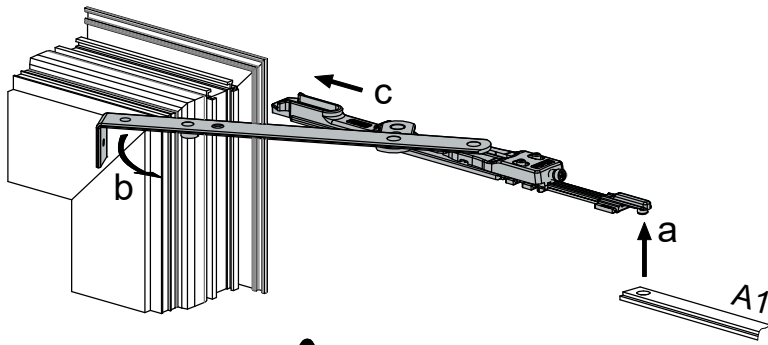

1447
 1447A
 1447B
 1447C

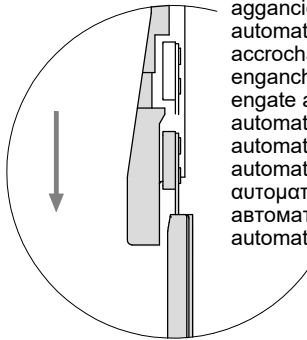
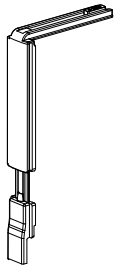

aggancio automatico
 automatic clamping
 accrochage automatique
 enganche automático
 engate automático
 automatische kupplung
 automatische koppeling
 automatyczne mocowanie
 αυτοματη συνδεση
 автоматическое сцепление
 avtomatsko zatvaranje

CLICK

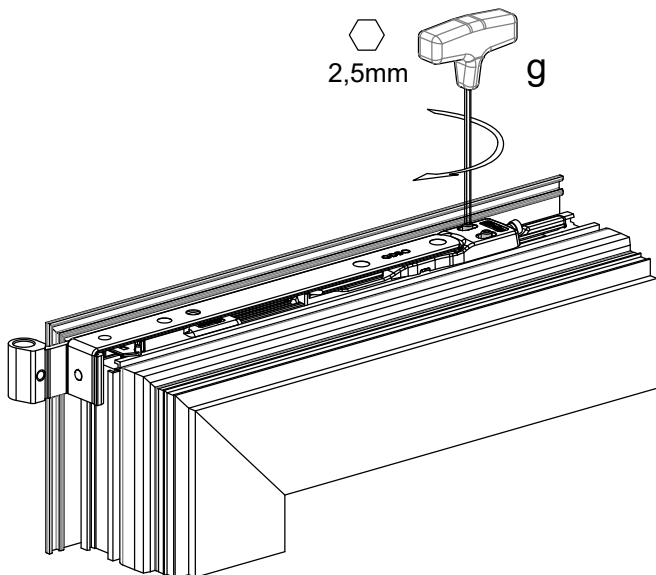
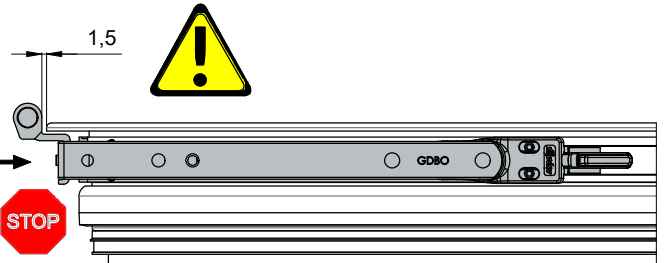
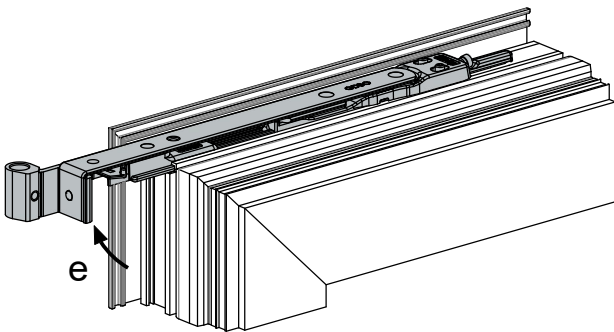
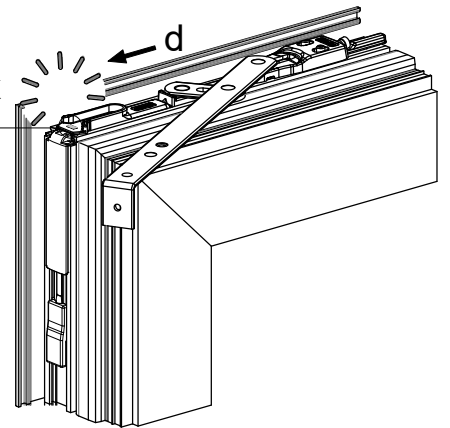

2,5mm

g

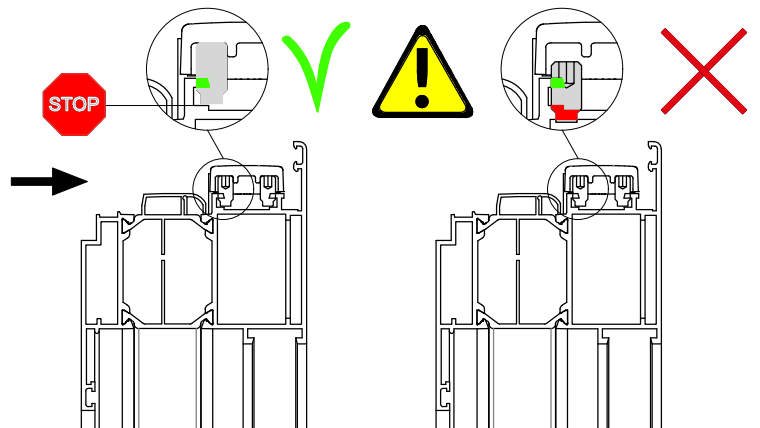

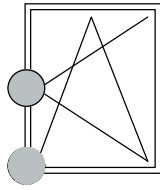

1461

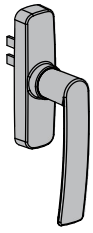

4

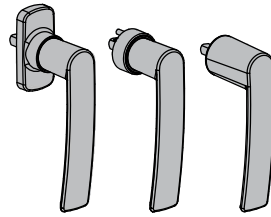
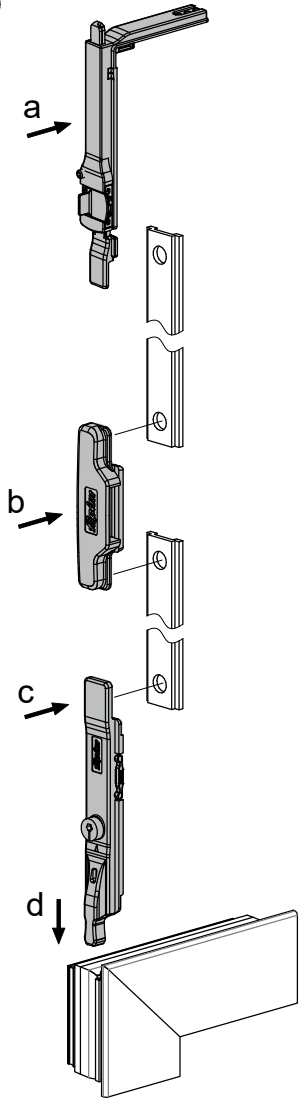

4

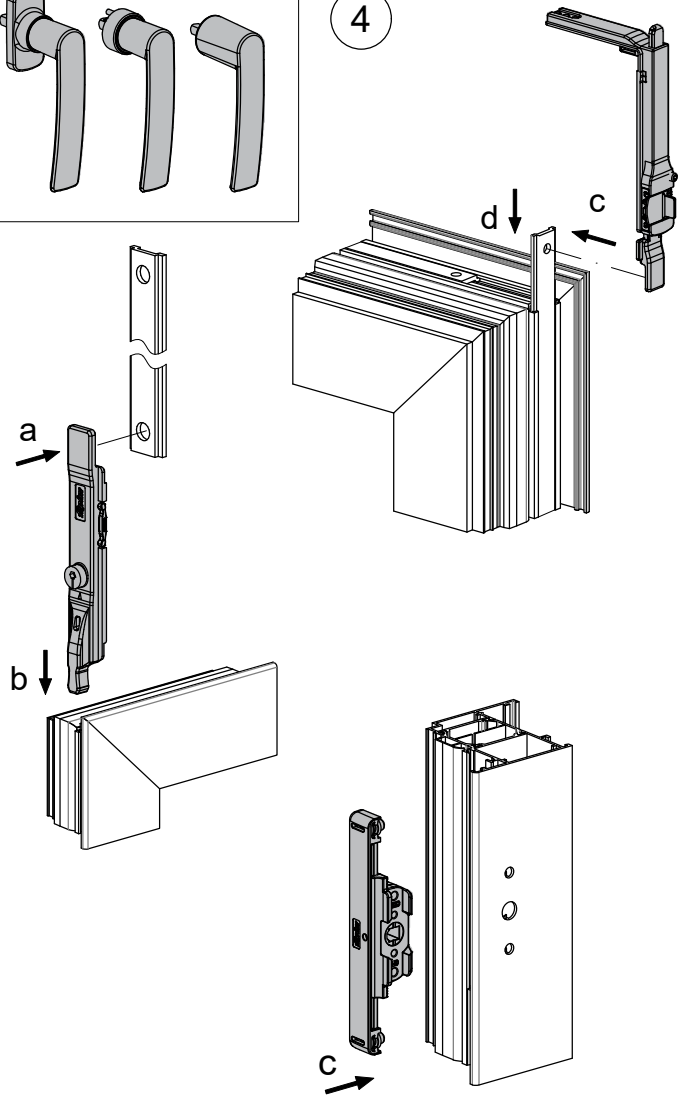

5

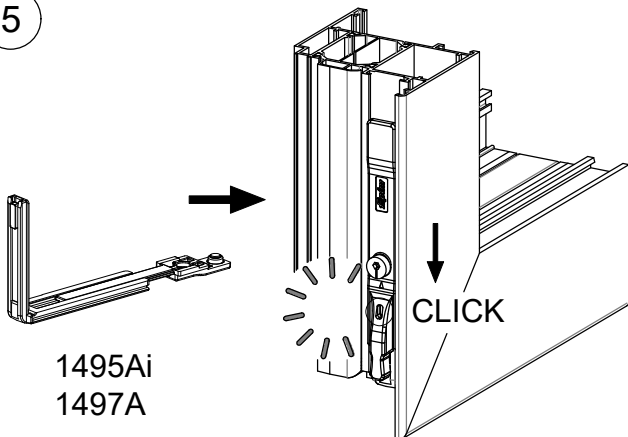

1495Ai
1497A

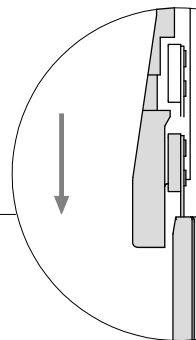

aggancio automatico
automatic clamping
accrochage automatique
enganche automático
engate automático
automatische kupplung
automatische koppelung
automatyczne mocowanie
αυτοματη συνδεση
автоматическое сцепление
automatsko zatvaranje

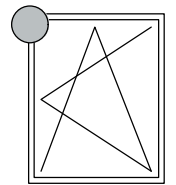
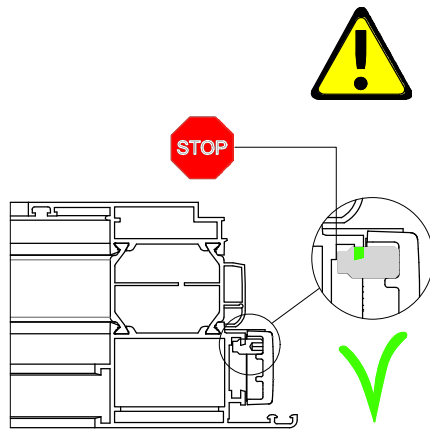
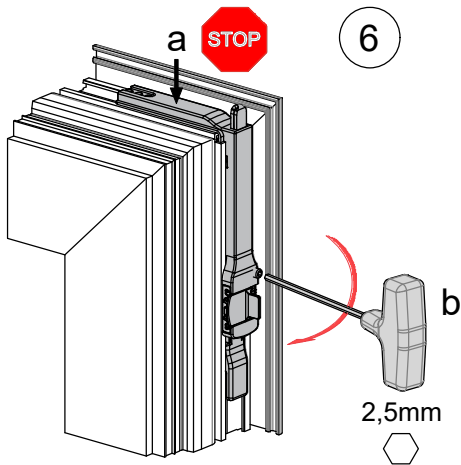

1461

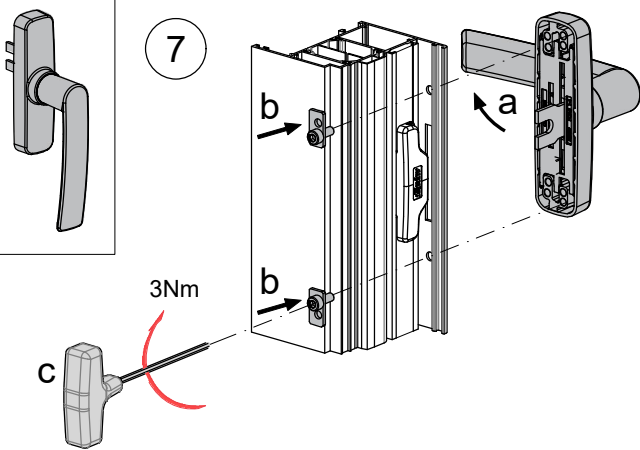

0520
0650
0651A



Vedi istruzioni
See instructions
Voir notice
Ver instrucciones
Siehe Anleitung
Zobacz instrukcje
Δείτε οδηγίες
Ознакомьтесь с инструкцией
Pogledajte uputstva

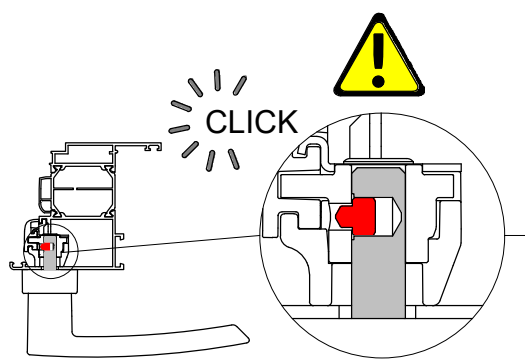
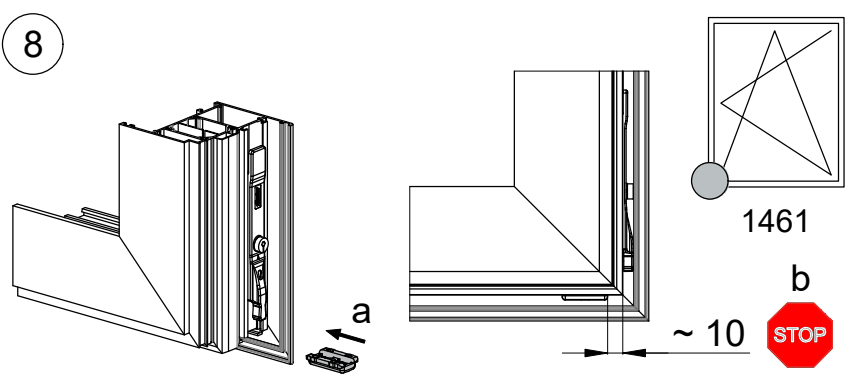
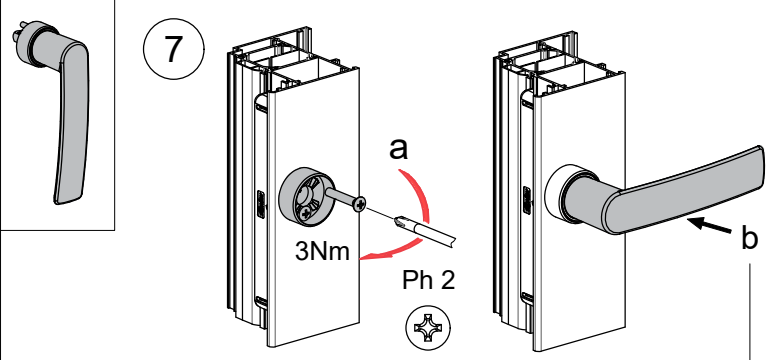
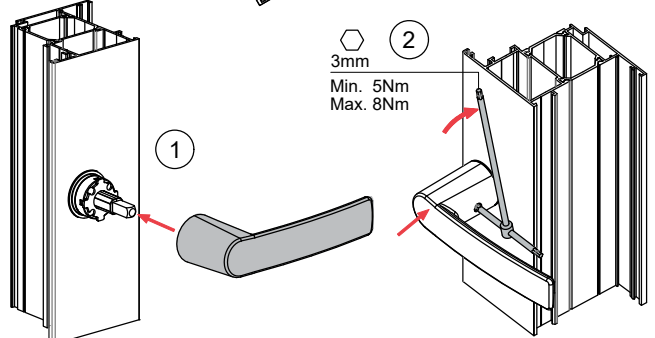
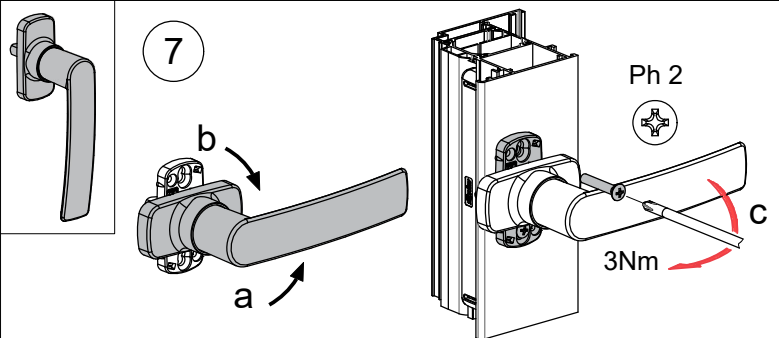

fapim
Life in evolution

9

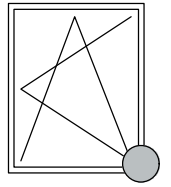
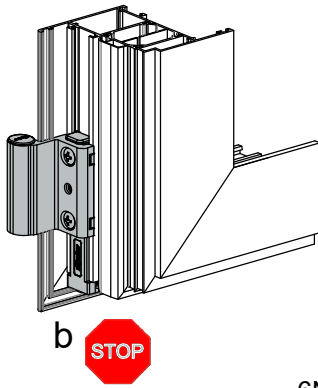
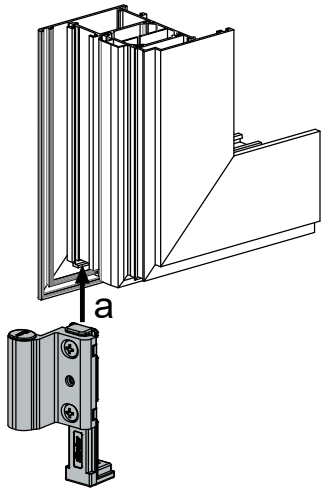

1410A

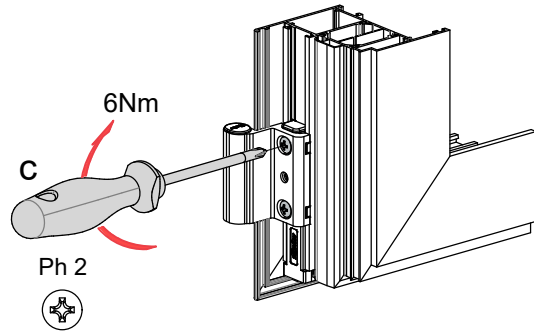

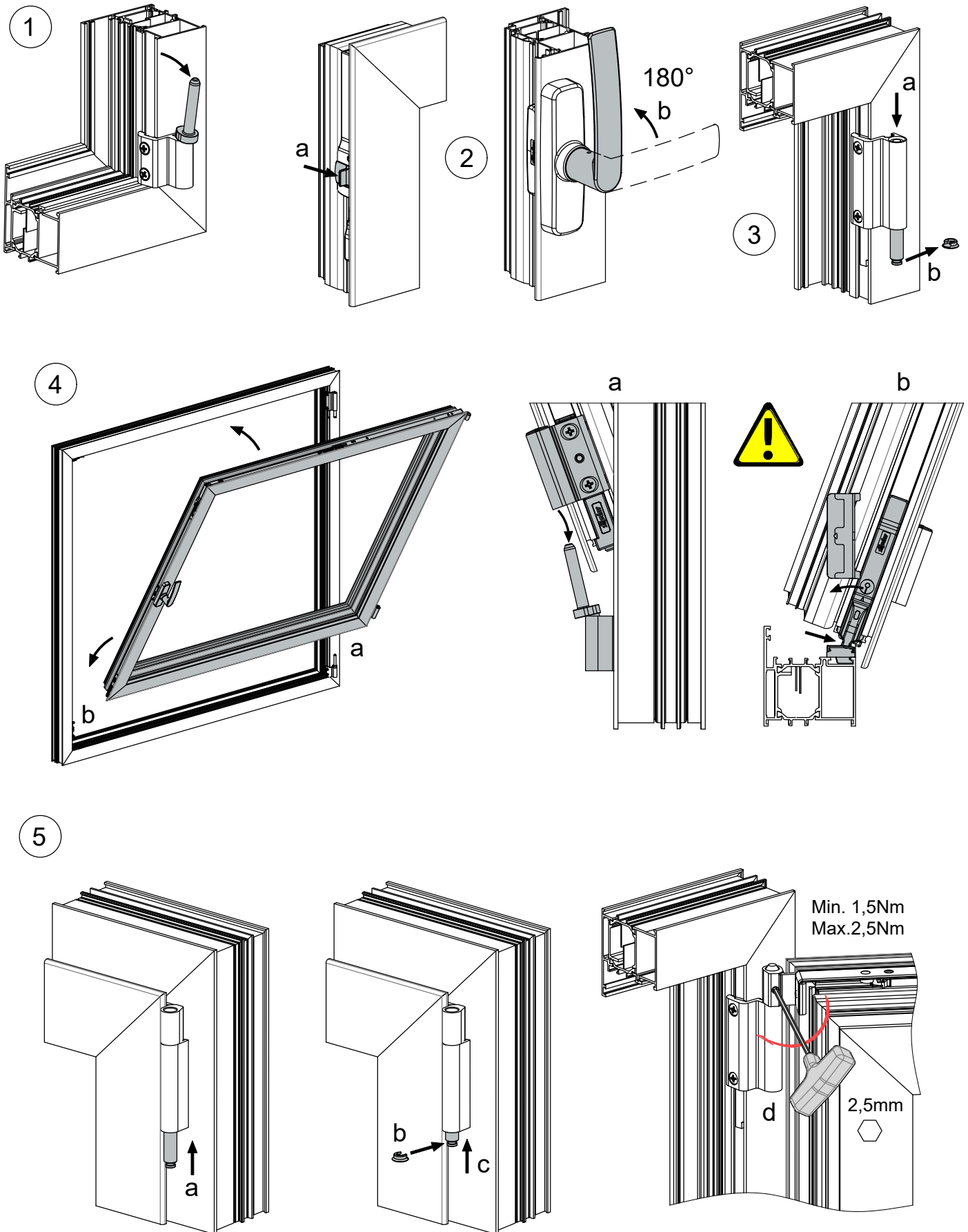

Kit di chiusura per anta abbinata - Locking kit for paired sash - Kit de fermeture pour ouvrant semi-fixe
 Kit de cierre para hoja pasiva - Kit de fechamento para folha passiva - Verschlusskit für zweiten Flügel
 Sluitkit voor tweede vleugel - Zestaw ryglujący do biernego skrzydła - Μηχανισμός δευτέρου φύλλου
 Запорный набор для второй створки - Mechanizam za drugo krilo

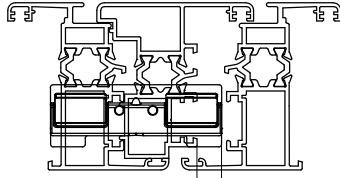
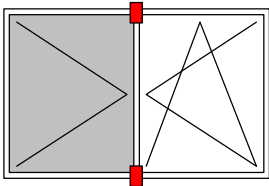

14.5

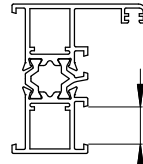

10 - 12
13,6-14

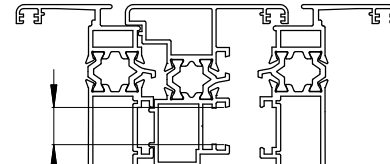

13,6-14

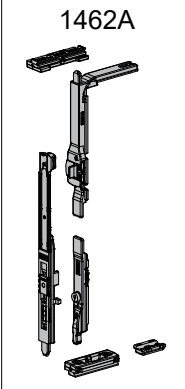

1462A

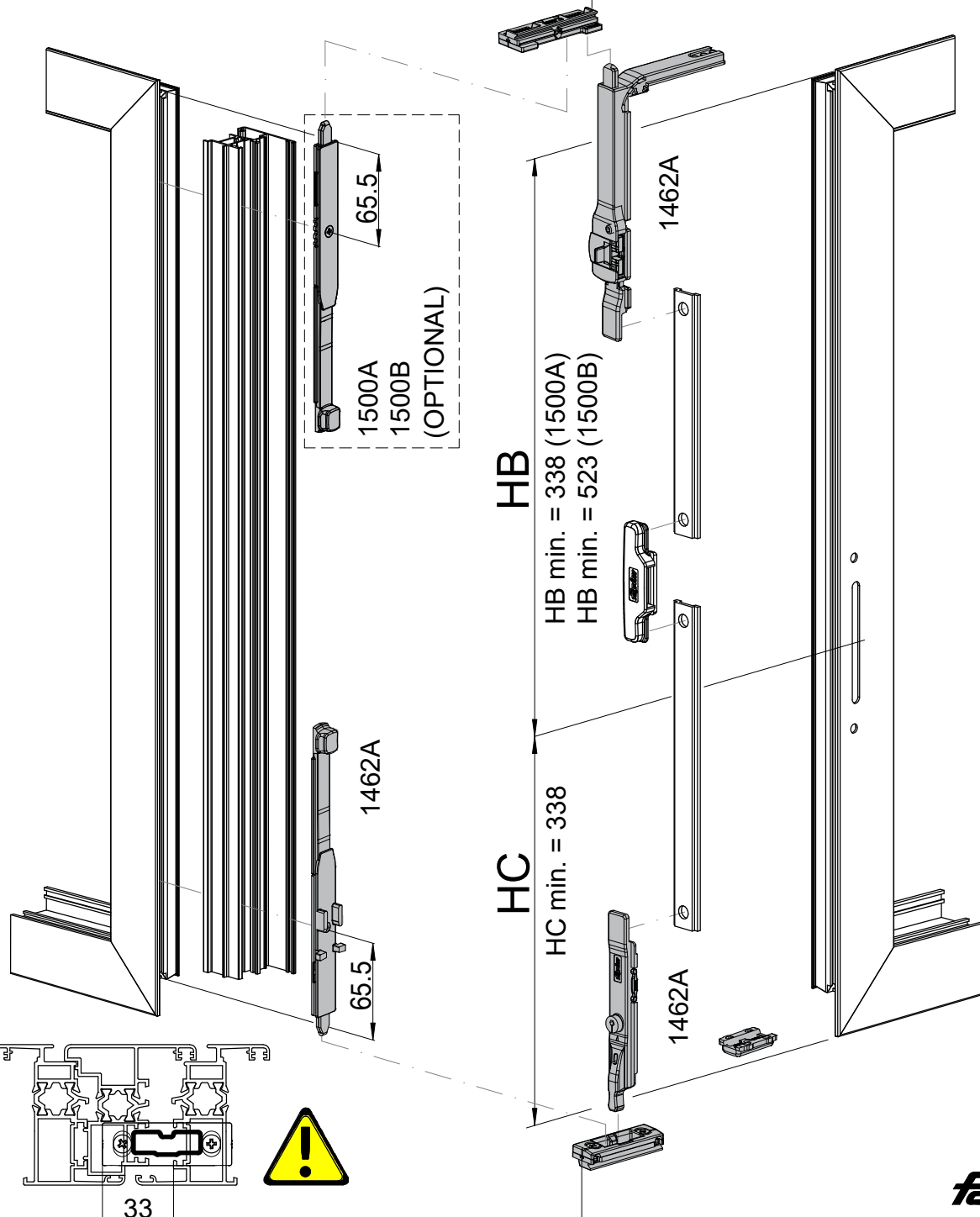

Kit di chiusura per anta abbinata - Locking kit for paired sash - Kit de fermeture pour ouvrant semi-fixe
 Kit de cierre para hoja pasiva - Kit de fecho para folha passiva - Verschlusskit für zweiten Flügel
 Sluutkit voor tweede vleugel - Zestaw ryglujący do biernego skrzydła - Μηχανισμός δευτέρου φύλλου
 Запорный набор для второй створки - Mehanizam za drugo krilo

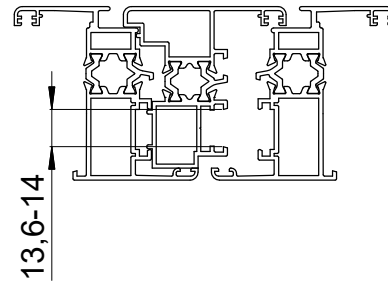
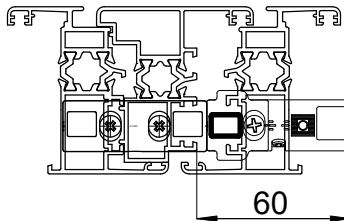
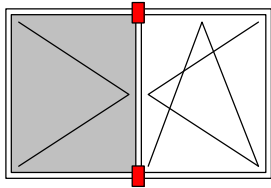

1503A

1503B

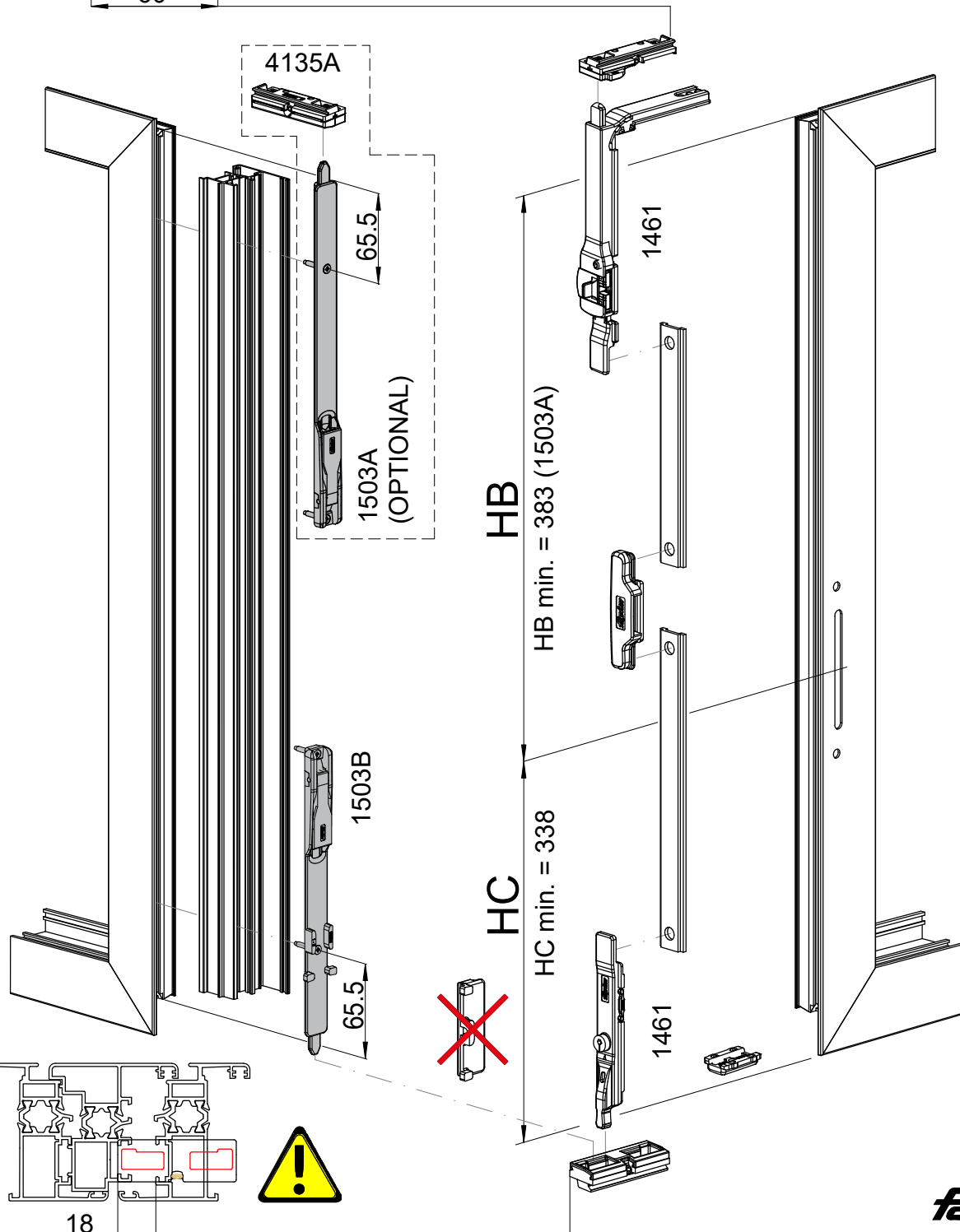
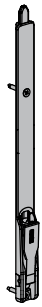

Kit di chiusura per anta abbinata - Locking kit for paired sash - Kit de fermeture pour ouvrant semi-fixe
 Kit de cierre para hoja pasiva - Kit de fechamento para folha passiva - Verschlusskit für zweiten Flügel
 Sluutkit voor tweede vleugel - Zestaw ryglujący do biernego skrzydła - Μηχανισμός δευτέρου φύλλου
 Запорный набор для второй створки - Mechanizem za drugo krilo

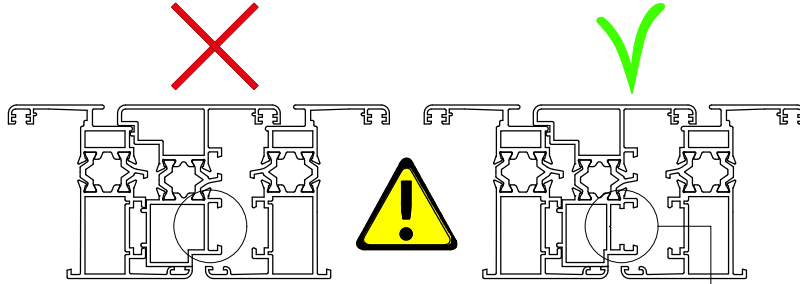
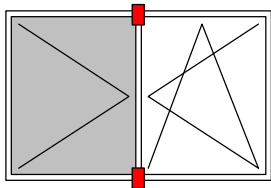

1508

1509A
1509B
1509C

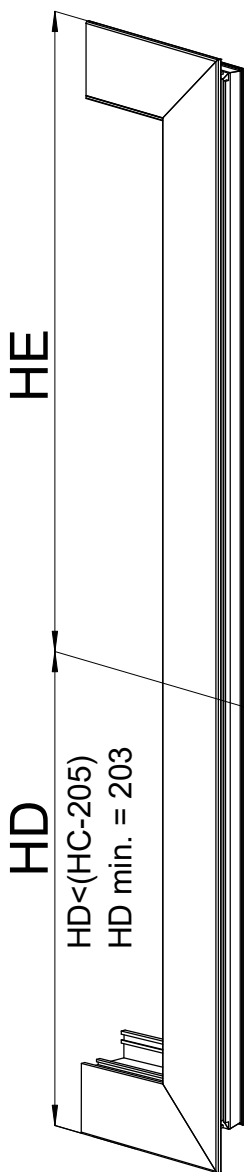
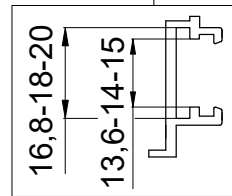
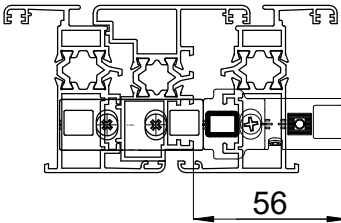
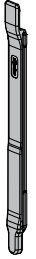
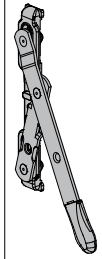

4135A

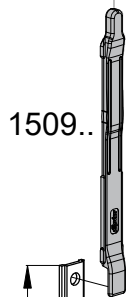
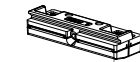

1508

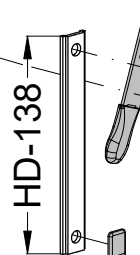

4135A

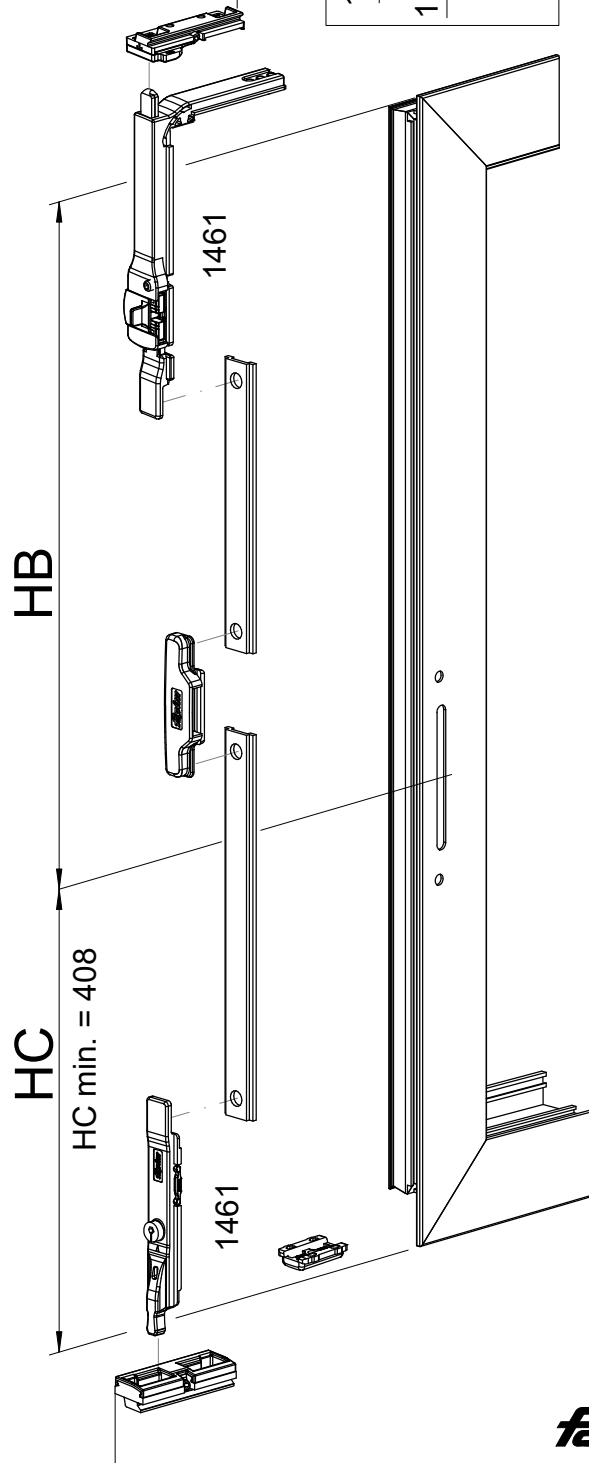
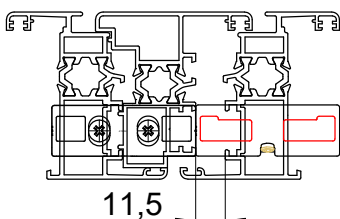
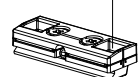

Kit di chiusura per anta abbinata - Locking kit for paired sash - Kit de fermeture pour ouvrant semi-fixe
 Kit de cierre para hoja pasiva - Kit de fechamento para folha passiva - Verschlusskit für zweiten Flügel
 Sluitkit voor tweede vleugel - Zestaw ryglujący do biernego skrzydła - Μηχανισμός δευτέρου φύλλου
 Запорный набор для второй створки - Mechanizam za drugo krilo

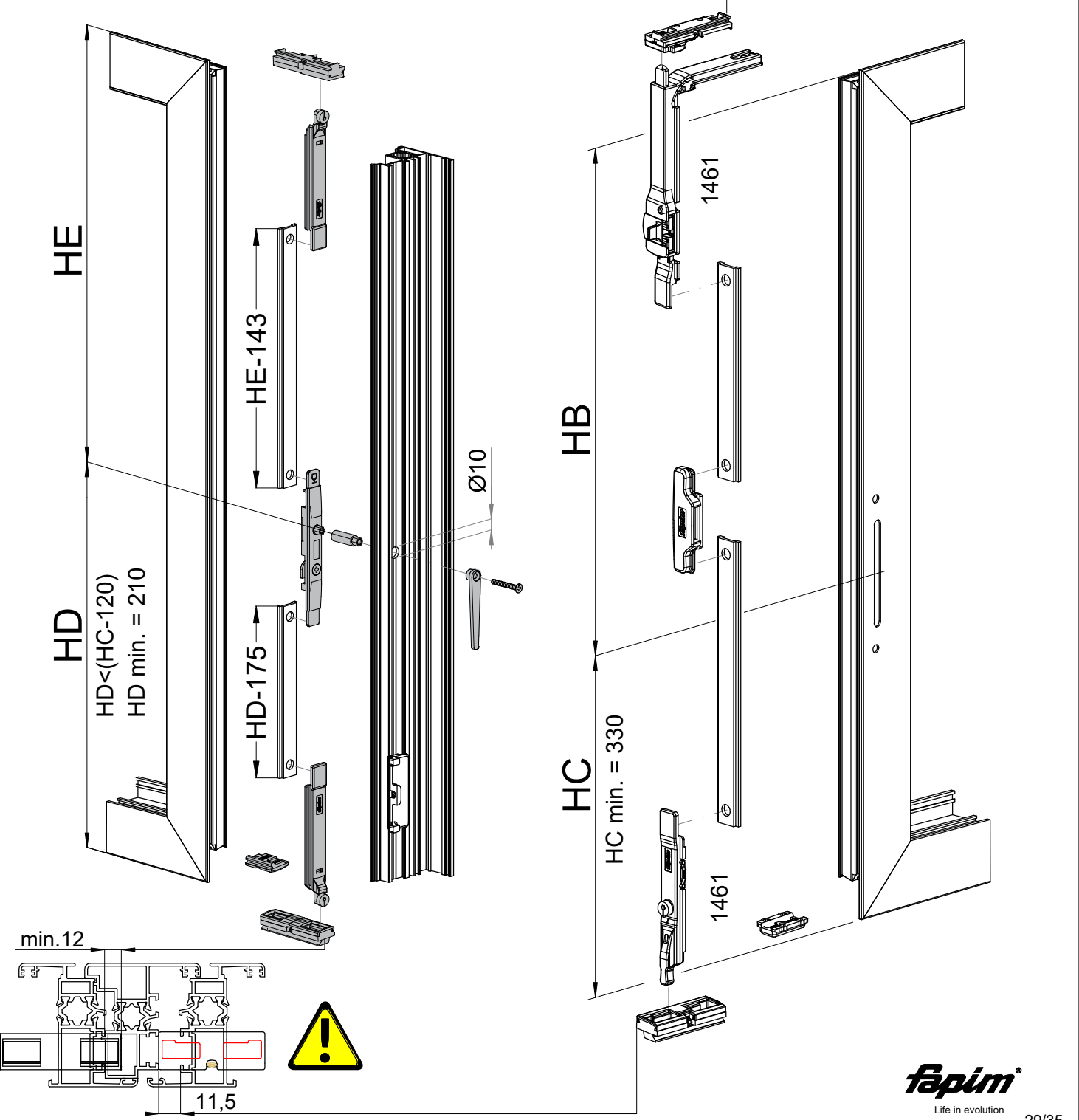
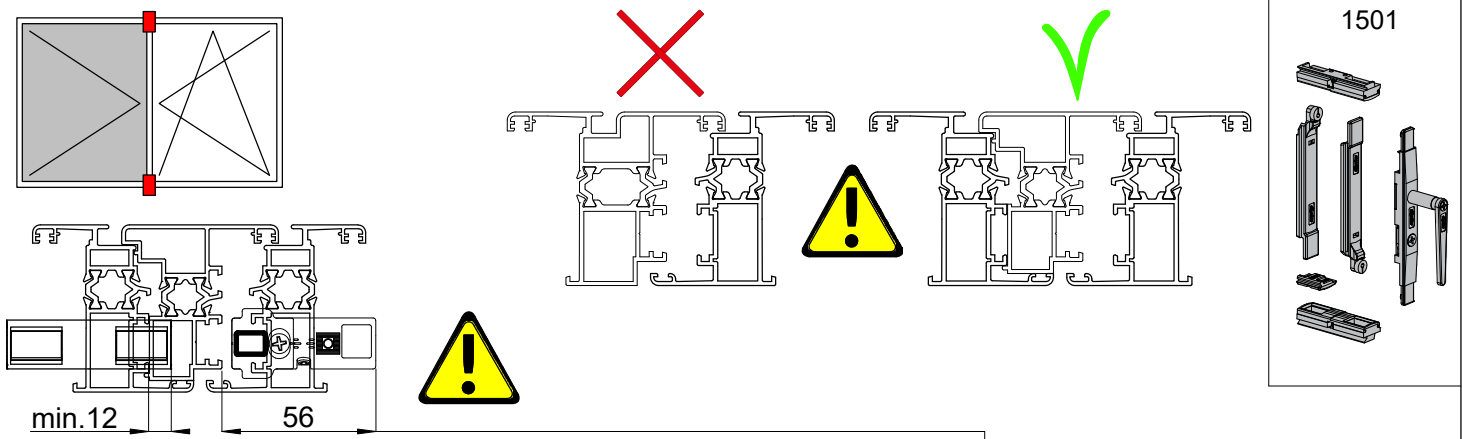

Coppia di cerniere per anta abbinata - Pair of hinges for paired sash - Paire de paumelles pour ouvrant semi-fixe
 Par de bisagras para hoja pasiva - Par de dobradicas para folha passiva - Bandpaar fur zweiten Flugel
 Paar scharnieren voor tweede vleugel - Komplet zawiasow do biernego skrzydła - Ζεύγος μεντεσέδων δευτέρου φύλλου
 Пара петель для второй створки - Par šarki za drugo krilo

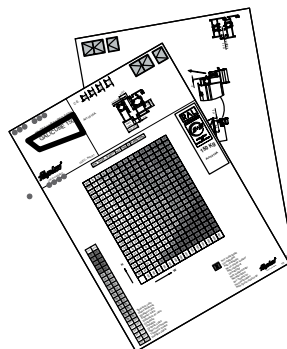
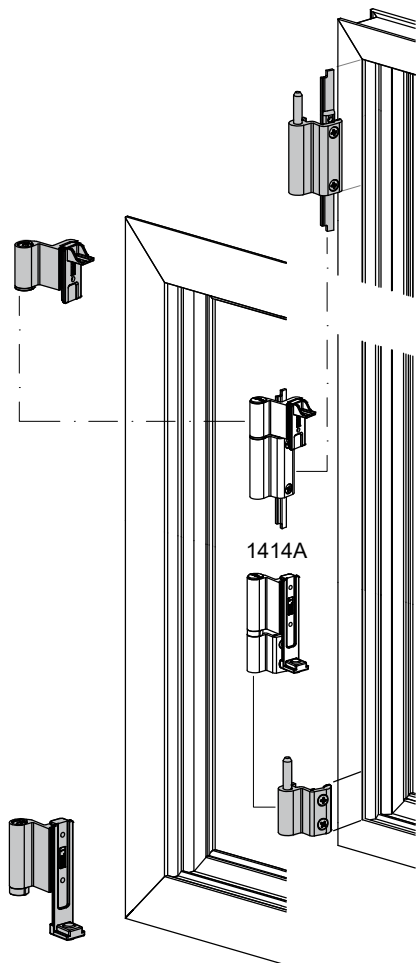
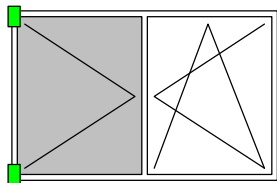

1414A

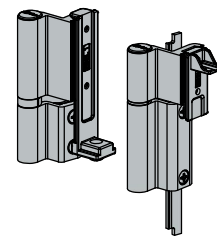

Vedi istruzioni - See instructions
 Voir notice - Ver instrucciones
 Siehe Anleitung - Zobacz instrukcje
 Δείτε οδηγίες - Ознакомьтесь с инструкцией - Pogledajte uputstva

Chiusura a contrasto - Clamping catch - Fermeture a contraste
 Cierre de contraste - Fecho de contraste - Klemmbarer Verschluss
 Ankersluitplaat - Docisk - Ασφάλεια φύλλου κάσας
 Скрытый прижим - Zatvaranje na kontrast

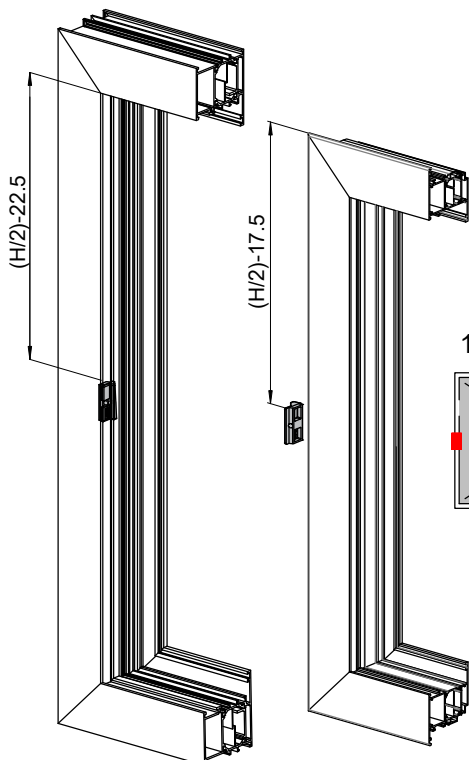

1400 < H < 1800

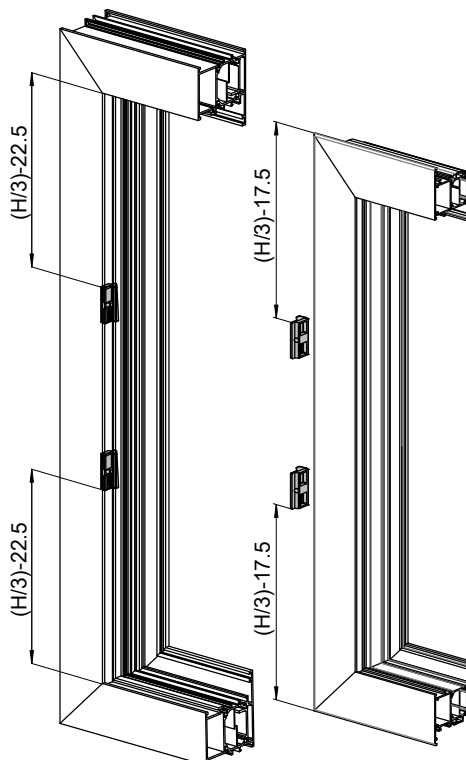
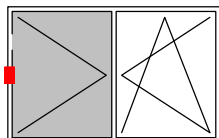

1800 < H < 3000

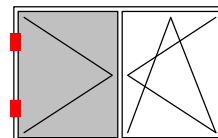

1622

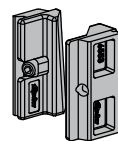

Regolazione - Adjustment - Réglage - Regulación - Regulação - Einstellungen
 Afstelling - Regulacja - Ρυθμίσεις - Регулировка - Prilagodavanje



1410A

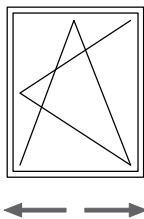
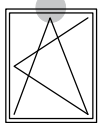
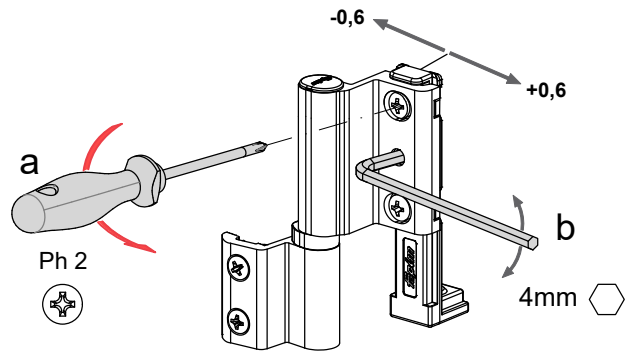
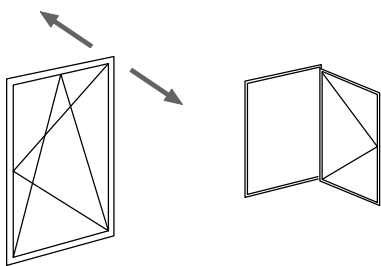
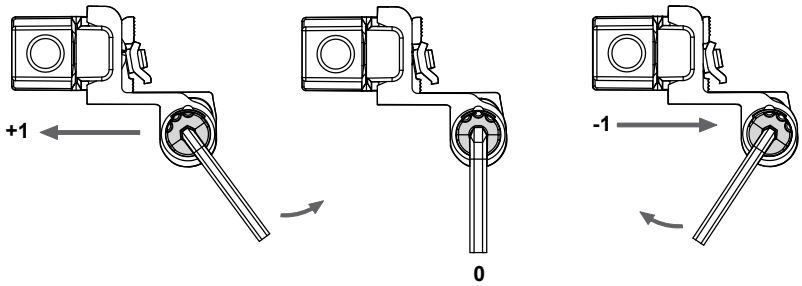
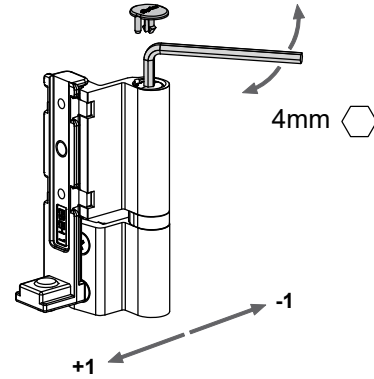
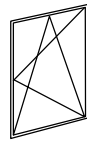
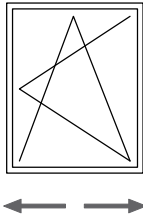
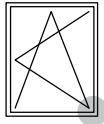
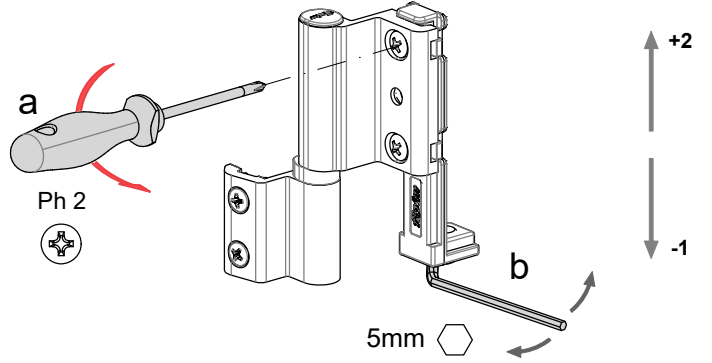
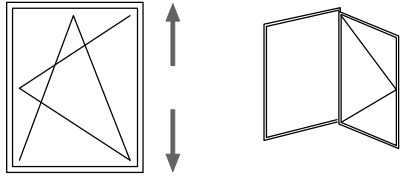

1447...

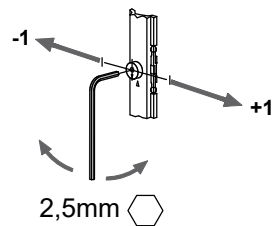
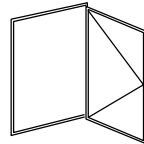
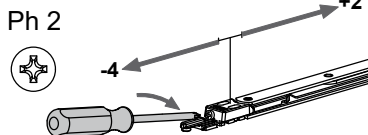
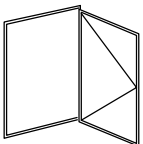

1585
 1593i
 1596i6
 1596C



1414A

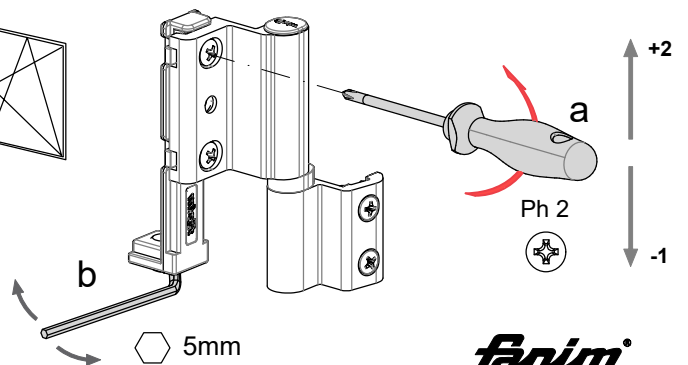
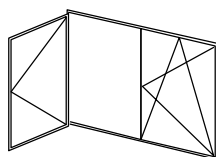
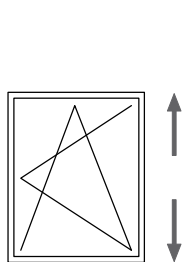
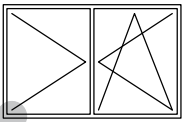
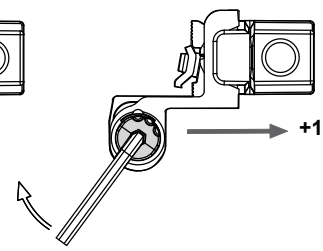
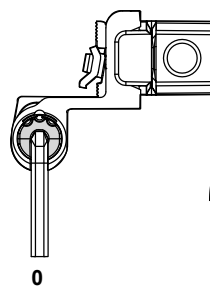
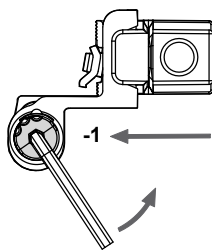
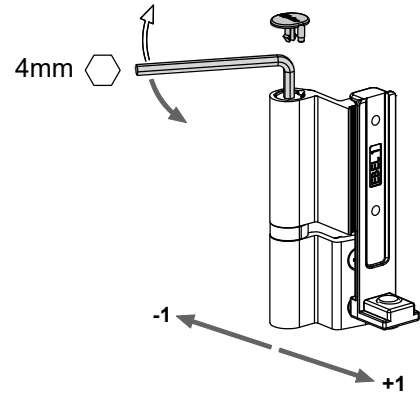
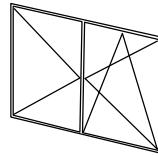
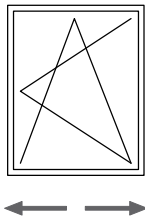
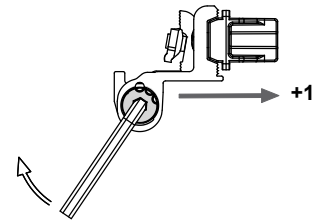
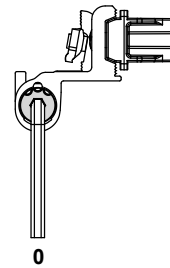
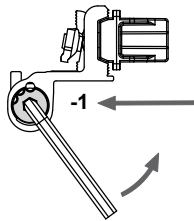
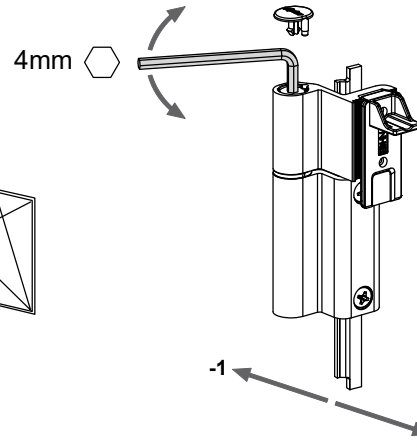
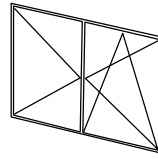
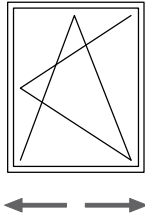
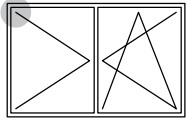

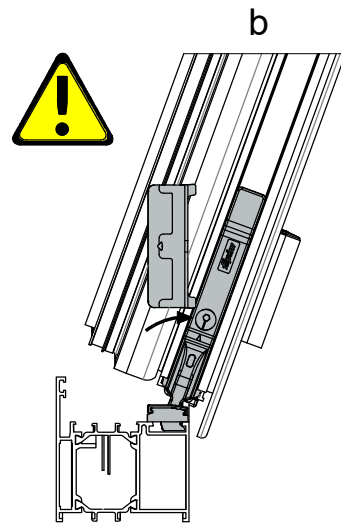
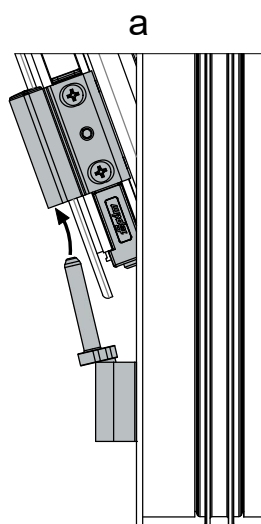
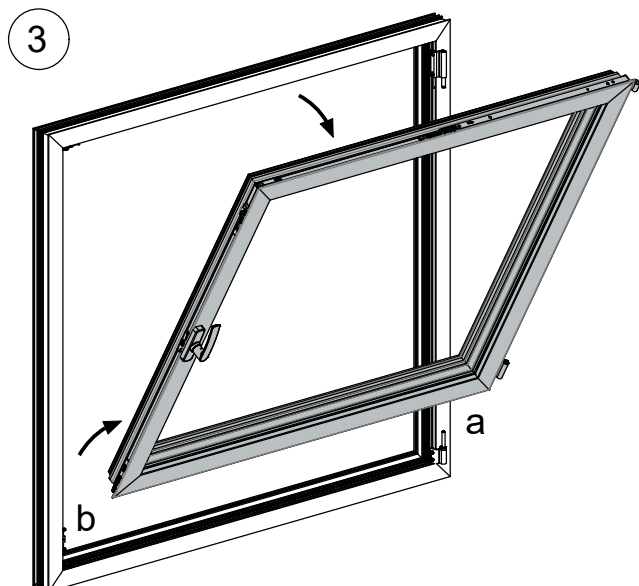
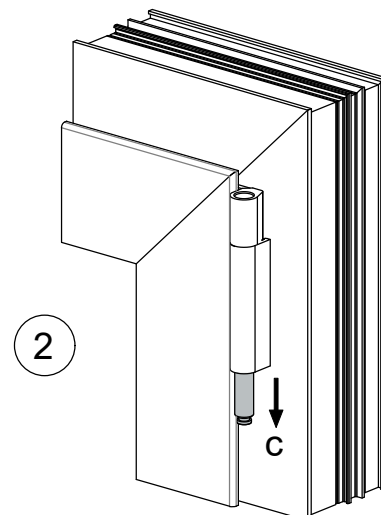
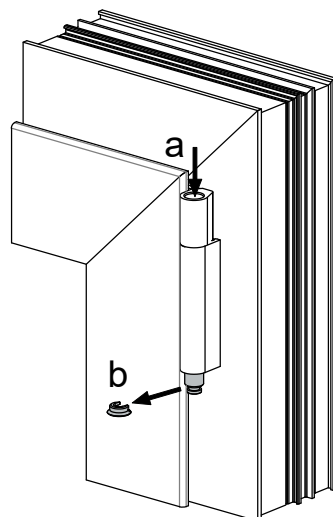
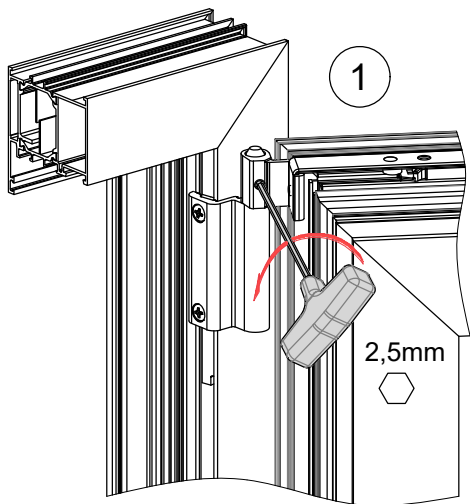



MODALITA' DI MANUTENZIONE

Lubrificare le parti mobili e punti di chiusura come indicato nello schema, con grasso a base calcio e classificazione NLGI grado 2, che abbia una temperatura d'impiego adeguata alle condizioni di utilizzo. Subito dopo l'installazione ed almeno ogni 6 mesi.

MAINTENANCE MODE

To grease all the movable parts and the locking points as given in the schema, with calcium-based grease of NLGI grade 2, which is suitable for the conditions of use. After installation and every 6 months at least.

MODALITÉ D'ENTRETIEN

Graisser les parties mobiles et les points de fermeture comme indiqué dans le schéma, avec une graisse à base de calcium de grade NLGI de grade 2, adaptée aux conditions d'utilisation. Immédiatement après l'installation et au moins tous les 6 mois.

MODALIDADES DE MANUTENCIÓN

Lubricar las partes muebles y los puntos de cierre como indicado en el esquema, con grasa a base de calcio de NLGI grado 2, adecuada a las condiciones de uso. Inmediatamente después de la instalación y al menos cada 6 meses.

MODALIDADES DE MANUTENÇÃO

Lubrifique as peças móveis e os pontos de fecho como indicado no esquema, com massa lubrificante à base de cálcio de grau NLGI grau 2, adequada às condições de utilização. Imediatamente após a instalação e, no mínimo, de 6 em 6 meses.

WARTUNGSBESTIMMUNGEN

Die beweglichen Teile und die Verschlusspunkte schmieren wie im Schema, mit einem Fett auf Kalziumbasis der NLGI Klasse 2, das für die Einsatzbedingungen geeignet ist. Unmittelbar nach dem Einbau und mindestens alle 6 Monate.

ONDERHOUDSPROCEDURE

Smeer bewegende delen en vergrendelpunten zoals aangegeven in het schema met vet op calciumbasis van NLGI klasse 2, dat geschikt is voor de gebruiksomstandigheden. Onmiddellijk na installatie en ten minste elke 6 maanden.

SPOSÓB KONSERWACJI

Nasmaruj ruchome części i punkty blokowania, jak pokazano na schemacie, smarem na bazie wapnia NLGI klasy 2, który jest odpowiedni do warunków użytkowania. Natychmiast po instalacji i co najmniej raz na 6 miesiące.

ΟΔΗΓΙΕΣ ΣΥΝΤΗΡΗΣΗΣ

Λιπάνετε τα κινούμενα μέρη και τα σημεία ασφάλισης, όπως φαίνεται στο διάγραμμα, με γράσο με βάση το ασβέστιο NLGI βαθμού 2, το οποίο είναι κατάλληλο για τις συνθήκες χρήσης. Αμέσως μετά την εγκατάσταση και τουλάχιστον κάθε 6 μήνες.

ФОРМЫ ОБСЛУЖИВАНИЯ

Смажьте подвижные части и точки фиксации, как показано на рисунке, смазкой на основе кальция NLGI класса 2, подходящей для условий эксплуатации. Сразу после установки и не реже одного раза в 6 месяца.

NAČINI ODRŽAVANJA

Подмажите покретне делове и тачке закључавања као што је приказано на дијаграму, машћу на бази калцијума и НЛГИ класификацијом степен 2, који има радну температуру погодну за услове употребе. Одмах након уградње и најмање свака 6 месеца.

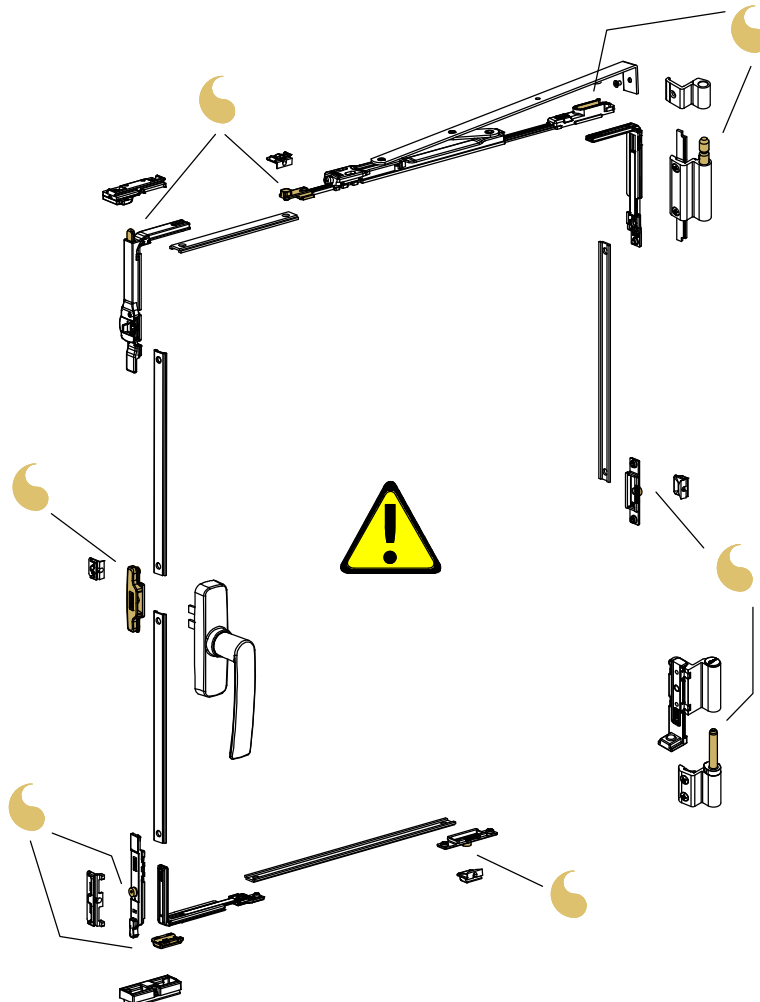



Prima della consegna della finestra al committente, il costruttore deve accertarsi che durante la fase di costruzione l'infisso non abbia subito danni derivati da un eventuale uso improprio. Oltre a seguire le istruzioni di montaggio e limitazioni d'uso, il costruttore deve anche conformarsi alle prescrizioni del documento "Responsabilità prodotto – Meccanismi anta-ribalta – REPR-AR" ed informare, di conseguenza, il committente; anche l'utilizzatore finale deve essere informato adeguatamente in merito. È possibile scaricare il documento REPR-AR dal sito web <http://www.fapim.it>.

Prior to delivering the window to the customer, manufacturer shall make sure that it did not suffer any damage during construction, due to improper use. In addition to following the assembly instructions and limits of use, manufacturer must comply with the requirements set out in the document "Product liability – Tilt and Turn mechanisms – REPR-AR" and inform the customer accordingly. The final user shall be adequately informed as well. The document REPR-AR can be downloaded from <http://www.fapim.it>

Avant de livrer la fenêtre au client, le constructeur doit vérifier que pendant la phase de construction la fenêtre n'ait pas subi des dommages à cause d'une utilisation pas correcte. Le constructeur doit suivre les notices d'assemblage et les limitations d'utilisation et aussi suivre les prescriptions du document "Responsabilité produit – mécanismes OB – REPR-AR" et en informer le client. L'utilisateur final aussi doit être bien informé au sujet. Il est possible de télécharger ce document REPR-AR du site web <http://www.fapim.it>.

Antes de la entrega de la ventana al cliente, el constructor tiene que averiguar que durante la fase de construcción el cerramiento no se haya dañado por usos impropios. Además de respetar las instrucciones de montaje y limitaciones de uso, el constructor tiene que conformarse a las prescripciones del documento "Responsabilidad producto – Mecanismos oscilo batiente- REPR-AR" e informar el cliente; aun el usuario final tiene que estar adecuadamente informado al respecto. Es posible descargar el documento REPR-AR del sitio <http://www.fapim.it>

Antes da janela ser entregue o cliente, o construtor tem que descobrir que, durante a fase de construção, o caixilho não tenha sido danificado por uso inadequado. Além de respeitar as instruções de montagem e limitações de uso, o construtor tem de estar em conformidade com os requisitos do documento "Responsabilidade do Produto - Mecanismos de oscilo batente REPR-AR" e informar o cliente, até mesmo o usuário final tem de ser devidamente informado. Você pode baixar o documento REPR-AR do site <http://www.fapim.it>

Vor dem Fenster an den Endkunden vom Hersteller geliefert wird, sollte der Hersteller überprüfen dass es Fenster keine Beschädigung hat durchgemacht durch unsachgemäßen Gebrauch während der Bauphase. Der Hersteller muss den Anweisungen folgen die auf den Montageplänen vorgesehen sind, sowie hinsichtlich der Nutzungsgrenzen und die Regeln folgen des Dokuments "Produktverantwortung – Drehkipp Beschlag- REPR-AR" und seinem Kunden darüber informieren. Der Endverbraucher muss auch gut über dieses Thema informiert werden. Man kann das Dokument REPR-AR von die Website <http://www.fapim.it> herunterladen.

Alvorens het raam aan de eindklant wordt geleverd moet de constructeur nagaan of gedurende de constructie faze het raam geen beschadigingen heeft ondergaan door een onjuist gebruik. De constructeur moet de instructies volgen die voorzien zijn op de montageplannen, alsook de gebruikslimieten respecteren en de voorschriften volgen van het document "Productverantwoordelijkheid – draaikip beslag-REPR-AR" en zijn klant hierover informeren. Ook de eindgebruiker moet goed geïnformeerd worden over dit onderwerp. Het is mogelijk het document REPR-AR te downloaden van de website <http://www.fapim.it>

Przed dostarczeniem stolarki do odbiorcy, producent zobowiązany jest do kontroli, czy w fazie produkcyjno montażowej nie doszło do uszkodzenia okuć. Producent, jest zobowiązany przestrzegać wytycznych dotyczących zastosowania i nośności okuć wraz z procedurami wyszczególnionymi w dokumencie " Odpowiedzialność za produkt, Mechanizm Rozwierno Uchylny REPR-AR ". Producent, zobowiązany jest do przekazania informacji zawartych w dokumencie odbiorcy, informacje w konsekwencji powinny być udostępnione użytkownikowi stolarki. Dokument REPR-AR można pobrać ze strony <http://www.fapim.it>

Πριν από την παράδοση του κουφώματος στον πελάτη, ο κατασκευαστής πρέπει να ελέγξει για τυχόν ζημιές και φθορές από λάθος χρήση. Επιπλέον πρέπει να ακολουθήσει τις οδηγίες συναρμολόγησης και τους περιορισμούς χρήσης, και να συμπληρώσει τα έγγραφα "Ευθύνη προϊόντος – Μηχανισμός ανάκλισης – REPR-AR" και να ενημερώσει τον πελάτη. Ο τελικός χρήστης θα πρέπει επίσης να ενημερωθεί. Το έγγραφο REPR-AR μπορείτε να το βρείτε στο <http://www.fapim.it>

Перед отправкой окна заказчику, изготовитель должен убедиться, что оно не имеет каких-либо повреждений. Изготовитель должен выполнить инструкции по сборке и данным по максимальным габаритам, а также требования, изложенные в документе "Ответственность за качество продукции – наклонно-поворотного механизма - Repr-AR" и информировать об этом клиента. Конечный потребитель должен быть надлежащим образом информирован. Документ Repr-AR можно загрузить с <http://www.fapim.it>

Pre isporuke prozora proizvođač je obavezan da prekontroliše da li u medjuvremenu nije došlo ni do kakvog oštećenja istog. Pored toga što je dužan da poštuje instrukcije montaže i dimenziona ograničenja proizvođač je obavezan da nakon što se u potpunosti upoznao sa dokumentom „Odgovornost za kvalitet proizvoda – okretno –zaokretni mehanizam – Repr_AR“ o svim detaljima obavesti i krajnjeg kupca. Od suštinske je važnosti da krajnji kupac bude adekvatno informisan. Dokument Repr-AR se može skinuti sa zvanične web adrese <http://www.fapim.it>